

REVO



OWNER'S MANUAL

Pride
Mobility Products Corp.
www.pridemobility.com

1-800-800-8586 (US) 1-888-570-1113 (Canada)

SAFETY GUIDELINES



WARNING! An authorized Pride Provider or qualified technician must perform the initial setup of this scooter and must perform all of the procedures in this manual.

The symbols below are used throughout this owner's manual and on the scooter to identify warnings and important information. It is very important for you to read them and understand them completely.



WARNING! Indicates a potentially hazardous condition/situation. Failure to follow designated procedures can cause either personal injury, component damage, or malfunction. On the product, this icon is represented as a black symbol on a yellow triangle with a black border.



MANDATORY! These actions should be performed as specified. Failure to perform mandatory actions can cause personal injury and/or equipment damage. On the product, this icon is represented as a white symbol on a blue dot with a white border.



PROHIBITED! These actions are prohibited. These actions should not be performed at any time or in any circumstances. Performing a prohibited action can cause personal injury and/or equipment damage. On the product, this icon is represented as a black symbol with a red circle and a red slash.

Please fill out the following information for quick reference:

Pride Provider:	_____
Address:	_____
Phone Number:	_____
Purchase Date:	_____
Serial Number:	_____

NOTE: This owner's manual is compiled from the latest specifications and product information available at the time of publication. We reserve the right to make changes as they become necessary. Any changes to our products may cause slight variations between the illustrations and explanations in this manual and the product you have purchased. The latest/current version of this manual is available on our website.

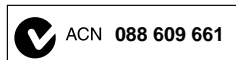

CONTENTS

I. INTRODUCTION.....	4
II. SAFETY	5
III. YOUR SCOOTER	19
IV. BATTERIES AND CHARGING	22
V. OPERATION	28
VI. COMFORT ADJUSTMENTS.....	30
VII. DISASSEMBLY AND ASSEMBLY	32
VIII. BASIC TROUBLESHOOTING	35
IX. CARE AND MAINTENANCE	37
X. WARRANTY	40
APPENDIX I - SPECIFICATIONS	42

I. INTRODUCTION

SAFETY

WELCOME to Pride Mobility Products Corporation (Pride). The product you have purchased combines state-of-the-art components with **safety**, comfort, and styling in mind. We are confident the design features will provide you with the conveniences you expect during your daily activities. Understanding how to **safely** operate and care for this product should bring you years of trouble-free operation and service.

Read and follow all instructions, warnings, and notes in this manual and all other accompanying literature before attempting to operate this product for the first time. In addition, your **safety** depends upon you, as well as your provider, caretaker, or healthcare professional in using good judgement.

If there is any information in this manual which you do not understand, or if you require additional assistance for setup or operation, please contact your authorized Pride Provider. **Failure to follow the instructions, warnings, and notes in this manual and those located on your Pride product can result in personal injury or product damage and will void Pride's product warranty.**

PURCHASER'S AGREEMENT

By accepting delivery of this product, you promise that you will not change, alter, or modify this product or remove or render inoperable or unsafe any guards, shields, or other safety features of this product; fail, refuse, or neglect to install any retrofit kits from time to time provided by Pride to enhance or preserve the safe use of this product.

SHIPPING AND DELIVERY

Before using your scooter, make sure your delivery is complete as some components may be individually packaged. If you do not receive a complete delivery, please contact your authorized Pride Provider immediately. Where damage has occurred during transport, either to the packaging or content, please contact the delivery company responsible.

INFORMATION EXCHANGE

We want to hear your questions, comments, and suggestions about this manual. We would also like to hear about the safety and reliability of your new scooter, and about the service you received from your authorized Pride Provider. Please notify us of any change of address, so we can keep you apprised of important information about safety, new products, and new options that can increase your ability to use and enjoy your scooter. Please feel free to contact us at the address below:

USA:

Pride Mobility Products Corporation
Attn.: Customer Care Department
182 Susquehanna Avenue
Exeter, PA 18643-2694
customer care@pridemobility.com
1-800-424-8205

Canada:

Pride Mobility Products Company
380 Vansickle Road Unit 350
St. Catharines, Ontario L2R 6P7
1-888-570-1113

NOTE: If you ever lose or misplace your product registration card or your copy of this manual, contact us and we will be glad to send you a new one immediately.

II. SAFETY

PRODUCT SAFETY SYMBOLS

The symbols below are used on the scooter to identify warnings, mandatory actions, and prohibited actions. It is very important for you to read and understand them completely.



Pinch/Crush points created during assembly.



Corrosive chemicals contained in battery.



EMI-RFI- This product has been tested and passed at an immunity level of 20 V/m.



Read and follow the information in the owner's manual.

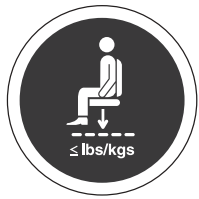

Maximum seating weight.



Unlocked and in freewheel mode.

Place unit on level ground and stand to one side when changing from drive mode to freewheel mode or freewheel mode to drive mode.

Locked and in drive mode.

II. SAFETY

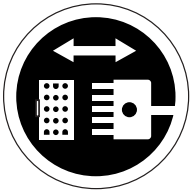

Front-to-rear plug orientation.



Do not remove anti-tip wheels.



Avoid exposure to rain, snow, ice, salt, or standing water whenever possible. Maintain and store in a clean and dry condition.



Removal of grounding prong can create electrical hazard. If necessary, properly install an approved 3-pronged adapter to an electrical outlet having 2-pronged plug access.

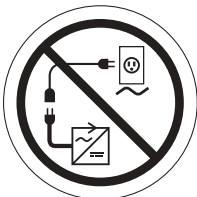

Do not connect an extension cord to the AC/DC converter or the battery charger.



Do not use a cell phone, walkie/talkie, laptop, or other radio transmitter while operating.



Disposal and recycling-Contact your authorized Pride Provider for information on proper disposal of your Pride product and its packaging.



II. SAFETY



Wear safety goggles.



Contains Lead.



Keep your hands away from the tires when driving. Be aware that loose fitting clothing can become caught in drive tires.



Explosive conditions exist!



Do not allow unsupervised children to play near the scooter while the batteries are charging.



Battery charger for indoor use only.

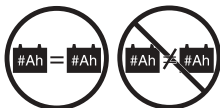

Do not use batteries with different amp-hour (Ah) capacities. Do not mix old and new batteries. Always replace both batteries at the same time.



Use only AGM or Gel-Cell batteries to reduce the risk of leakage or explosive conditions.

II. SAFETY



Do not lift the mobility vehicle while seated in it.



Do not lift the mobility vehicle while seated in it.

II. SAFETY

GENERAL



MANDATORY! Do not operate your new scooter for the first time without completely reading and understanding this owner's manual.

Your scooter is a state-of-the-art life-enhancement device designed to increase mobility. Pride provides an extensive variety of products to best fit the individual needs of the scooter user. Please be aware that the final selection and purchasing decision regarding the type of scooter to be used is the responsibility of the scooter user, who is capable of making such a decision, and his/her healthcare professional (i.e., medical doctor, physical therapist, etc.).

The contents of this manual are based on the expectation that a mobility device expert has properly fitted the scooter to the user and has assisted the prescribing healthcare professional and/or the authorized Pride Provider in the instruction process for the use of the product.

There are certain situations, including some medical conditions, where the scooter user will need to practice operating the scooter in the presence of a trained attendant. A trained attendant can be defined as a family member or care professional specially trained in assisting a scooter user in various daily living activities.

As you begin using your scooter during daily activities, you will probably encounter situations in which you will need some practice. Simply take your time and you will soon be in full and confident control as you maneuver through doorways, on and off elevators, up and down ramps, and over moderate terrain.

Below are some precautions, tips, and other safety considerations that will help you become accustomed to operating the scooter safely.

MODIFICATIONS

Pride has designed and engineered your scooter to provide maximum mobility and utility. A wide range of accessories is available from your authorized Pride Provider to further customize your scooter to better suit your needs and/or preferences. However, under no circumstances should you modify, add, remove, or disable any feature, part, or function of your scooter.



WARNING! Do not modify your scooter in any way not authorized by Pride. Do not use accessories if they have not been tested or approved for Pride products.

REMOVABLE PARTS



WARNING! Do not attempt to lift or move your scooter by any of its removable parts, including the armrests, seat, or shroud.

II. SAFETY

PRE-RIDE SAFETY CHECK

Get to know the feel of your scooter and its capabilities. Pride recommends that you perform a safety check before each use to make sure your scooter operates smoothly and safely.

Perform the following inspections prior to using your scooter:

- Check for proper tire inflation. Maintain but do not exceed the psi/bar/kPa air pressure rating indicated on each tire if equipped with pneumatic tires.
- Check all electrical connections. Make sure they are tight and not corroded.
- Check all harness connections. Make sure they are secured properly.
- Check the brakes.
- Check battery charge.

If you discover a problem, contact your authorized Pride Provider for assistance.

TIRE INFLATION

If your scooter is equipped with pneumatic tires, you should check or have the air pressure checked regularly. Proper inflation pressures will prolong the life of your tires and help ensure the smooth operation of your scooter.



WARNING! It is critically important that the psi/bar/kPa air pressure rating indicated on the tire be maintained in pneumatic tires at all times. Do not underinflate or overinflate your tires. Low pressure may result in loss of control, and overinflated tires may burst. Failure to maintain the psi/bar/kPa air pressure rating indicated on the pneumatic tires at all times may result in tire and/or wheel failure.

WARNING! Inflate your scooter tires from a regulated air source with an available pressure gauge. Inflating your tires from an unregulated air source could overinflate them.

NOTE: If the tire on your scooter lists the psi rating only, use the following conversion formulas to find the bar or kPa rating: $bar = psi \times 0.06895$; $kPa = psi \times 6.89476$.

WEIGHT LIMITATIONS

Your scooter is rated for a maximum weight capacity. Refer to the specifications table for information.



MANDATORY! Stay within the specified weight capacity for your scooter. Exceeding the weight capacity voids your warranty. Pride will not be held responsible for injuries and/or property damage resulting from failure to observe weight limitations.



WARNING! Do not carry passengers on your scooter. Carrying passengers on your scooter may affect the center of gravity, resulting in a tip or a fall.

INCLINE INFORMATION

More and more buildings have ramps with specified degrees of inclination, designed for easy and safe access. Some ramps may have turning switchbacks (180-degree turns) that require you to have good cornering skills on your scooter.

- Proceed with extreme caution as you approach the downgrade of a ramp or other incline.
- Take wide swings with your scooter around any tight corners. If you do that, the scooter's rear wheels will follow a wide arc, not cut the corner short, and not bump into or get hung up on any railing corners.
- When driving down a ramp, keep the scooter's speed adjustment set to the slowest speed setting to ensure a safely controlled descent.
- Avoid sudden stops and starts.

II. SAFETY

When climbing an incline, try to keep your scooter moving. If you must stop, start up again slowly, and then accelerate cautiously. When driving down an incline, do so by setting the speed adjustment dial to the slowest setting and driving in the forward direction only. If your scooter starts to move down the incline faster than you anticipated or desired, allow it to come to a complete stop by releasing the throttle control lever. Then push the throttle control lever forward slightly to ensure a safely controlled descent.

WARNING! When on any sort of an incline or decline, never place the scooter in freewheel mode, especially when seated on it or standing next to it.

WARNING! When climbing an incline, do not zigzag or drive at an angle up the face of the incline. Drive your scooter straight up the incline. This greatly reduces the possibility of a tip or a fall. Always exercise extreme caution when negotiating an incline.



WARNING! Do not drive your scooter across the side of an incline or diagonally up or down an incline; do not stop, if possible, while driving up or down an incline.

WARNING! You should not travel up or down a potentially hazardous incline (i.e., areas covered with snow, ice, cut grass, or wet leaves).

WARNING! Even though your scooter is capable of climbing slopes greater than those illustrated in figure 1, do not, under any circumstances, exceed the incline guidelines or any other specifications presented in this manual. Doing so could cause instability in your scooter.

Handicap public access ramps are not subject to government regulation in all countries, and therefore do not necessarily share the same standard percent of slope. Other inclines may be natural or, if man-made, not designed specifically for scooters. Figures 1, 1A, and 1B illustrate your scooter's stability and its ability to climb grades under various weight loads and under controlled testing conditions.

These tests were conducted with the scooter's seat in the highest position and adjusted rearward on the seat base to its farthest rearward position. Use this information as a guideline. Your scooter's ability to travel up inclines is affected by your weight, your scooter's speed, your angle of approach to the incline, and your scooter setup.



WARNING! Any attempt to climb or descend a slope steeper than what is shown in figures 1, 1A, and 1B may put your scooter in an unstable position and cause it to tip.

WARNING! Never carry an oxygen tank weighing more than 15 lbs. (6.8 kg). Never fill the rear basket with contents exceeding 15 lbs. (6.8 kg).

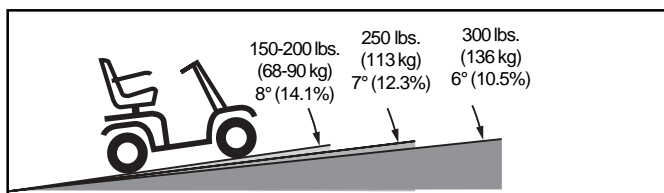

Figure 1. 3-wheel Maximum Recommended Incline Angles

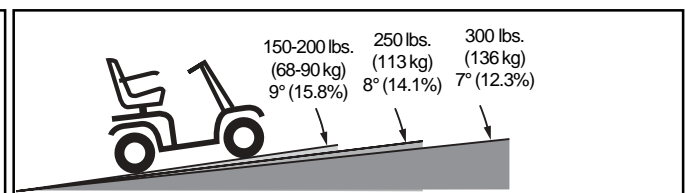

Figure 1A. 4-wheel Maximum Recommended Incline Angles

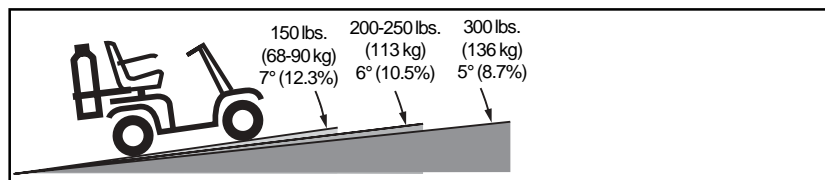

Figure 1B. Maximum Recommended Incline Angles (With Oxygen Tank)

II. SAFETY

When you approach an incline, it is best to lean forward. See figures 2 and 2A. This shifts the center of gravity of you and your scooter toward the front of the scooter for improved stability.

NOTE: When negotiating ramps, if the throttle control lever is released while moving forward, the powered scooter may "roll back" approximately 1 foot (30.48 cm) before the brake engages. If the throttle control lever is released while moving in reverse, the powered scooter may "roll back" approximately 3 feet (1 meter) before the brake engages.

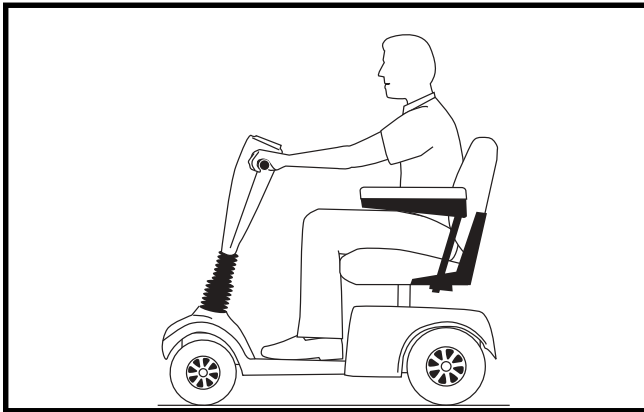

Figure 2. Normal Driving Position

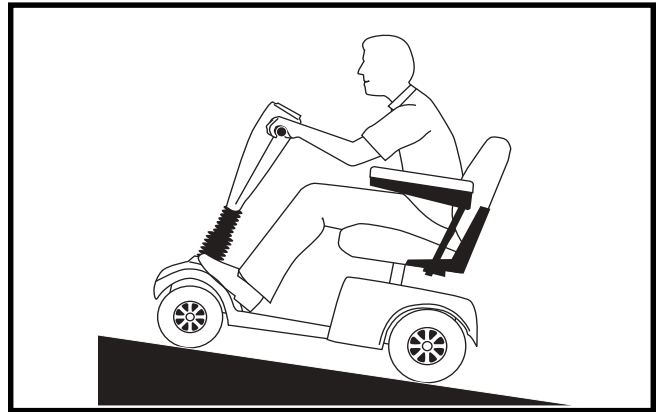

Figure 2A. Increased Stability Driving Position

CORNERING INFORMATION

Excessively high cornering speeds can create the possibility of tipping. Factors which affect the possibility of tipping include, but are not limited to, cornering speed, steering angle (how sharply you are turning), uneven road surfaces, inclined road surfaces, riding from an area of low traction to an area of high traction (such as passing from a grassy area to a paved area—especially at high speed while turning), and abrupt directional changes. High cornering speeds are not recommended. If you feel that you may tip over in a corner, reduce your speed and steering angle (i.e., lessen the sharpness of the turn) to prevent your scooter from tipping.



WARNING! When cornering sharply, reduce your speed and maintain a stable center of gravity. When using your scooter at higher speeds, do not corner sharply. This greatly reduces the possibility of a tip or fall. Always exercise common sense when cornering.

BRAKING INFORMATION

Your scooter is equipped with these powerful brake systems:

- **Regenerative:** Uses electricity to rapidly slow the vehicle when the throttle control lever returns to the center/stop position.
- **Disc Park Brake:** Activates mechanically after regenerative braking slows the vehicle to near stop, or when power is removed from the system for any reason.

II. SAFETY

OUTDOOR DRIVING SURFACES

Your scooter is designed to provide optimum stability under normal driving conditions—dry, level surfaces composed of concrete, blacktop, or asphalt. However, Pride recognizes that there will be times when you will encounter other surface types. For this reason, your scooter is designed to perform admirably on packed soil, grass, and gravel. Feel free to use your scooter safely on lawns and in park areas.

- Reduce your scooter's speed when driving on uneven terrain and/or soft surfaces.
- Avoid tall grass that can become tangled in the running gear.
- Avoid loosely packed gravel and sand.
- If you feel unsure about a driving surface, avoid that surface.

PUBLIC STREETS AND ROADWAYS



WARNING! You should not operate your scooter on public streets and roadways. Be aware that it may be difficult for traffic to see you when you are seated on your scooter. Obey all local pedestrian traffic rules. Wait until your path is clear of traffic, and then proceed with extreme caution.

STATIONARY OBSTACLES (STEPS, CURBS, ETC.)

WARNING! Do not drive near raised surfaces, unprotected ledges, and/or drop-offs (curbs, porches, stairs, etc.).

WARNING! Do not attempt to have your scooter climb or descend an obstacle that is inordinately high.



WARNING! Do not attempt to have your scooter proceed backward down any step, curb, or other obstacle. This may cause the scooter to tip.

WARNING! Be sure your scooter is traveling perpendicular to any curb you may be required to ascend or descend. See figures 3 and 3A.

WARNING! Do not attempt to negotiate a curb that has a height greater than 2 in. (5 cm).

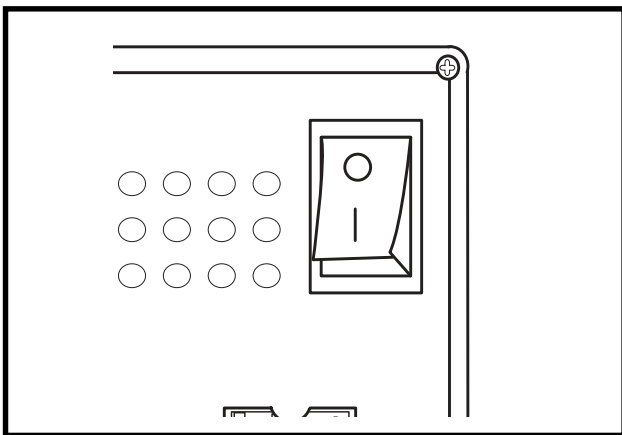

Figure 3. Correct Curb Approach

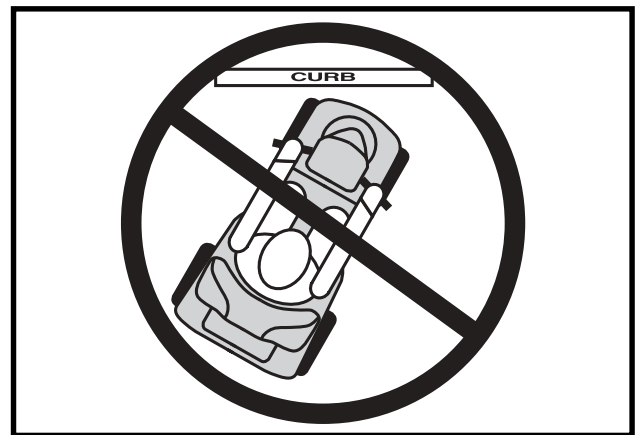

Figure 3A. Incorrect Curb Approach

II. SAFETY

INCLEMENT WEATHER PRECAUTIONS

Exposure of your scooter to inclement weather conditions should be avoided whenever possible. If suddenly caught up in rain, snow, severe cold or heat while operating your scooter, proceed to shelter at the earliest opportunity. Thoroughly dry your scooter before storing, charging, or operating your scooter.



PROHIBITED! Operating in rain, snow, salt, mist/spray conditions, and on icy/slippery surfaces can cause personal injury and/or damage to the scooter and electrical system. Maintain and store your scooter in a dry and clean condition.



WARNING! Prolonged exposure to hot or cold conditions may affect the temperature of upholstered and non-upholstered items on the scooter, possibly resulting in skin irritation. Exercise caution when using your scooter in extremely hot or cold conditions or when exposing your scooter to direct sunlight for prolonged periods of time.

FREEWHEEL MODE

Your scooter is equipped with a manual freewheel lever that, when engaged, allows the scooter to be pushed. For more information about how to place your scooter into and out of freewheel mode, see III. “Your Scooter.”



WARNING! When your scooter is in freewheel mode, the braking system is disengaged.

- Disengage the drive motors only on a level surface.
- Ensure the key is removed from the key switch.
- Stand to one side of the scooter to engage or disengage freewheel mode. Never sit on a scooter to do this.
- After you have finished pushing your scooter, always return it to drive mode to lock the brakes.

An added feature built into the scooter is “push-too-fast” protection, which safeguards the scooter against gaining excessive speed while in freewheel mode.

“Push-too-fast” operates differently depending on which of two conditions exists:

- If the key is switched “off” while in freewheel mode, the scooter’s controller activates regenerative braking when the scooter is pushed faster than a maximum threshold which has been preprogrammed. In this case, the controller is acting as a speed governor.
- If the key is switched “on” while in freewheel mode, you will encounter considerable resistance at any speed. This prevents the scooter from gaining unwanted momentum should the manual freewheel lever inadvertently be released while driving the scooter.

STAIRS AND ESCALATORS

Scooters are not designed to travel up or down stairs or escalators. Always use an elevator.



WARNING! Do not use your scooter to negotiate steps or escalators.

DOORS

- Determine if the door opens toward or away from you.
- Use your hand to turn the knob or push the handle or push-bar.
- Drive your scooter gently and slowly forward to push the door open. Or drive your scooter gently and slowly backwards to pull the door open.

II. SAFETY

ELEVATORS

Modern elevators have a door edge safety mechanism that, when pushed, reopens the door(s).

- If you are in the doorway of an elevator when the door(s) begin to close, push on the rubber door edge or allow the rubber door edge to contact the scooter and the door will reopen.
- Use care that pocketbooks, packages, or scooter accessories do not become caught in elevator doors.

NOTE: *If your scooter's turning radius is greater than 60 in. (152.4 cm), it may be difficult to maneuver in elevators and building entrances. Use caution when attempting to turn or maneuver your scooter in small spaces, and avoid areas that might pose a problem.*

LIFT/ELEVATION PRODUCTS

If you will be traveling with your scooter, you may find it necessary to use a lift/elevation product to aid in transportation. Pride recommends that you closely review the instructions, specifications, and safety information set forth by the manufacturer of the lift/elevation product before using that product.



WARNING! Never sit on your scooter when it is being used in connection with any type of lift/elevation product. Your scooter was not designed with such use in mind and any damage or injury incurred from such use is not the responsibility of Pride.

BATTERIES

In addition to following the warnings below, be sure to comply with all other battery handling information.



MANDATORY! Battery posts, terminals, and related accessories contain lead and lead compounds. Wear goggles and gloves when handling and wash hands after handling.

WARNING! Scooter batteries are heavy. See specifications table. If you are unable to lift that much weight, be sure to get help. Use proper lifting techniques and avoid lifting beyond your capacity.



WARNING! Always protect the batteries from freezing and never charge a frozen battery. Charging a frozen battery may result in damage to the battery.

WARNING! Connect the battery harnesses in the proper manner. RED (+) cables must be connected to positive (+) battery terminals/posts. BLACK (-) cables must be connected to negative (-) battery terminals/posts. Protective caps should be installed over all battery terminals. REPLACE cables immediately if damaged.

BATTERY DISPOSAL AND RECYCLING

If you encounter a damaged or cracked battery, immediately enclose it in a plastic bag. Contact your local waste disposal agency or authorized Pride Provider for instructions on disposal and battery recycling, which is our recommended course of action.

PREVENTING UNINTENDED MOVEMENT



WARNING! If you anticipate being seated in a stationary position for an extended period of time, turn off the power. This will prevent unexpected motion from inadvertent throttle control lever contact.

II. SAFETY

MOTOR VEHICLE TRANSPORT

Pride recommends that you do not remain seated in your scooter while traveling in a motor vehicle. The scooter should be stowed in the trunk of a car or in the back of a truck or van with the batteries removed and properly secured.

WARNING! Although your scooter may be equipped with a positioning belt, this belt is not designed to provide restraint during motor vehicle transport. Anyone travelling in a motor vehicle should be properly secured in the motor vehicle seat with safety belts fastened securely.



WARNING! Do not sit on your scooter while it is in a moving vehicle.

WARNING! Always be sure your scooter and its batteries are properly secured when it is being transported. Batteries should be secured in an upright position and protective caps should be installed on the battery terminals. Batteries should not be transported with any flammable or combustible items.

GETTING ONTO AND OFF OF YOUR SCOOTER

Getting onto and off of your scooter requires a good sense of balance. Please observe the following safety tips when getting onto and off of your scooter:

- Remove the key from the key switch.
- Ensure that your scooter is not in freewheel mode. See III. “Your Scooter.”
- Make certain that the seat is secured in place.
- Pivot the armrests up to make getting onto and off of the scooter easier.

WARNING! Position yourself as far back as possible in the scooter seat to prevent the scooter from tipping.



WARNING! Avoid putting all of your weight on the scooter armrests and do not use the armrests for weight bearing purposes, such as transfers. Such use may cause the scooter to tip, resulting in a fall from the scooter.

WARNING! Avoid putting all of your weight on the floorboard. Such use may cause the scooter to tip.

REACHING AND BENDING

Avoid reaching or bending while driving your scooter. Bending forward creates the risk of accidental throttle control lever contact. Bending to the side while seated creates the risk of tipping. It is important to maintain a stable center of gravity and keep the scooter from tipping. Pride recommends that the scooter user determine his/her personal limitations and practice bending and reaching in the presence of a qualified attendant.



WARNING! Do not bend, lean, or reach for objects if you have to pick them up from the scooter deck or from either side of the scooter. Movements such as these may change your center of gravity and the weight distribution of the scooter and cause your scooter to tip.



PROHIBITED! Keep your hands away from the tires when driving. Be aware that loose fitting clothing can become caught in drive tires.

II. SAFETY

POSITIONING BELTS

Your authorized Pride Provider, therapist(s), and other healthcare professionals are responsible for determining your requirement for a positioning belt in order to operate your scooter safely.



WARNING! If you require a positioning belt to safely operate your scooter, make sure it is fastened securely.

PRESCRIPTION DRUGS/PHYSICAL LIMITATIONS

The scooter user must exercise care and common sense when operating his/her scooter. This includes awareness of safety issues when taking prescribed or over-the-counter drugs or when the user has specific physical limitations.



WARNING! Consult your physician if you are taking prescribed or over-the-counter medication or if you have certain physical limitations. Some medications and limitations may impair your ability to operate your scooter in a safe manner.

ALCOHOL/SMOKING

The scooter user must exercise care and common sense when operating his/her scooter. This includes awareness of safety issues while under the influence of alcohol or while smoking.

WARNING! Do not operate your scooter while you are under the influence of alcohol, as this may impair your ability to drive safely.



WARNING! Pride strongly recommends that you do not smoke cigarettes while seated in your scooter, although the scooter has passed the necessary testing requirements for cigarette smoking. You must adhere to the following safety guidelines if you decide to smoke cigarettes while seated in your scooter.

- Do not leave lit cigarettes unattended.
- Keep ashtrays a safe distance from the seat cushions.
- Always make sure cigarettes are completely extinguished before disposal.

ELECTROMAGNETIC AND RADIO FREQUENCY INTERFERENCE (EMI/RFI)



WARNING! Laboratory tests have shown that electromagnetic and radio frequency waves can have an adverse affect on the performance of electrically-powered mobility vehicles.

Electromagnetic and Radio Frequency Interference can come from sources such as cellular phones, mobile two-way radios (such as walkie-talkies), radio stations, TV stations, amateur radio (HAM) transmitters, wireless computer links, microwave signals, paging transmitters and medium-range mobile transceivers used by emergency vehicles. In some cases, these waves can cause unintended movement or damage to the control system. Every electrically-powered mobility vehicle has an immunity (or resistance) to EMI. The higher the immunity level, the greater the protection against EMI. This product has been tested and has passed at an immunity level of 20 V/M.



WARNING! Be aware that cell phones, two-way radios, laptops, and other types of radio transmitters may cause unintended movement of your electrically-powered mobility vehicle due to EMI. Exercise caution when using any of these items while operating your mobility vehicle and avoid coming into close proximity of radio and TV stations.

II. SAFETY



WARNING! The addition of accessories or components to the electrically-powered mobility vehicle can increase the susceptibility of the vehicle to EMI. Do not modify your scooter in any way not authorized by Pride.

WARNING! The electrically-powered mobility vehicle itself can disturb the performance of other electrical devices located nearby, such as alarm systems.

NOTE: For further information on EMI/RFI, visit the Resource Center on www.pridemobility.com. If unintended motion or brake release occurs, turn your scooter off as soon as it is safe to do so. Contact your authorized Pride Provider to report the incident.

III. YOUR SCOOTER

TILLER CONSOLE

The tiller console houses all of the controls needed to drive your scooter, including the speed adjustment dial, key switch, status LED, throttle control lever, battery condition meter, running lights switch, and horn buttons. See figure 4.



PROHIBITED! Do not expose the tiller console to moisture. In the event that the tiller console does become exposed to moisture, do not attempt to operate your scooter until the tiller console has dried thoroughly.

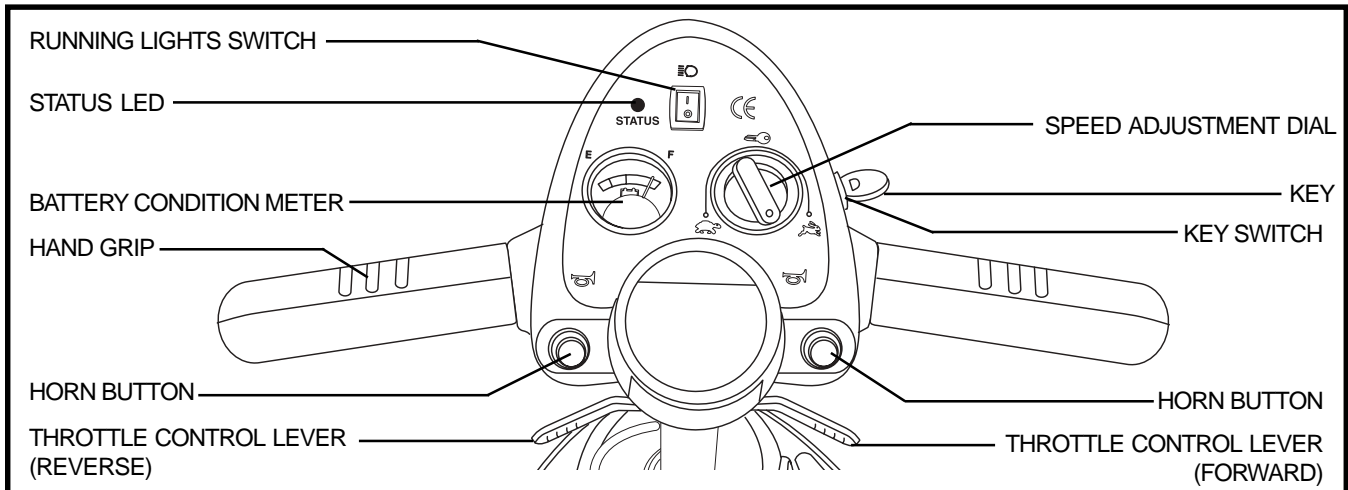

Figure 4. Tiller Console

Key Switch

- Insert the key into the key switch and turn it clockwise to power up (turn on) your scooter.
- Turn the key counterclockwise to power down (turn off) your scooter.

Although the key can be left in the key switch when the scooter is powered down, we recommend removing it to prevent unauthorized use of your scooter.



WARNING! If the key is moved to the “off” position while your scooter is in motion, the electronic brakes engage and your scooter will come to an abrupt stop!

Throttle Control Lever

This lever allows you to control the forward speed and the reverse speed of your scooter up to the maximum speed you preset with the speed adjustment dial.

- Place your right hand on the right handgrip and your left hand on the left handgrip.
- Use your right thumb to push the right side of the lever to disengage your scooter’s brakes and move forward.
- Release the lever and allow your scooter to come to a complete stop before pushing the other side of the lever to move in reverse.
- When the throttle is completely released, it automatically returns to the center “stop” position and engages your scooter’s brakes.

Running Lights Switch

This button controls your scooter’s front and rear running lights.

- Toggle the switch forward to turn on the running lights.
- Toggle the switch rearward to turn off the running lights.

III. YOUR SCOOTER

Horn Buttons

These buttons activate a warning horn. Your scooter must be turned on for the horn to be operational. Do not hesitate to use the warning horn when doing so may prevent accident or injury.

Status LED

The status LED will alert you to electrical problems that may occur with the scooter. The LED remains constantly lit while your scooter is on. If the scooter develops an electrical problem, the status LED will flash a code. See VIII. “Basic Troubleshooting” for flash codes.

Battery Condition Meter

When the key is fully inserted and turned clockwise to power up your scooter, this meter indicates the approximate battery voltage strength. For further information on battery charging, see IV. “Batteries and Charging.”

Speed Adjustment Dial

This dial allows you to preselect and limit your scooter’s top speed.

- The image of the tortoise represents the slowest speed setting.
- The image of the hare represents the fastest speed setting.

REAR SECTION

The manual freewheel lever, anti-tip wheels, battery packs, main circuit breaker (reset button), and the motor/transaxle assembly (not shown) are located on the rear section of your scooter. See figure 5.

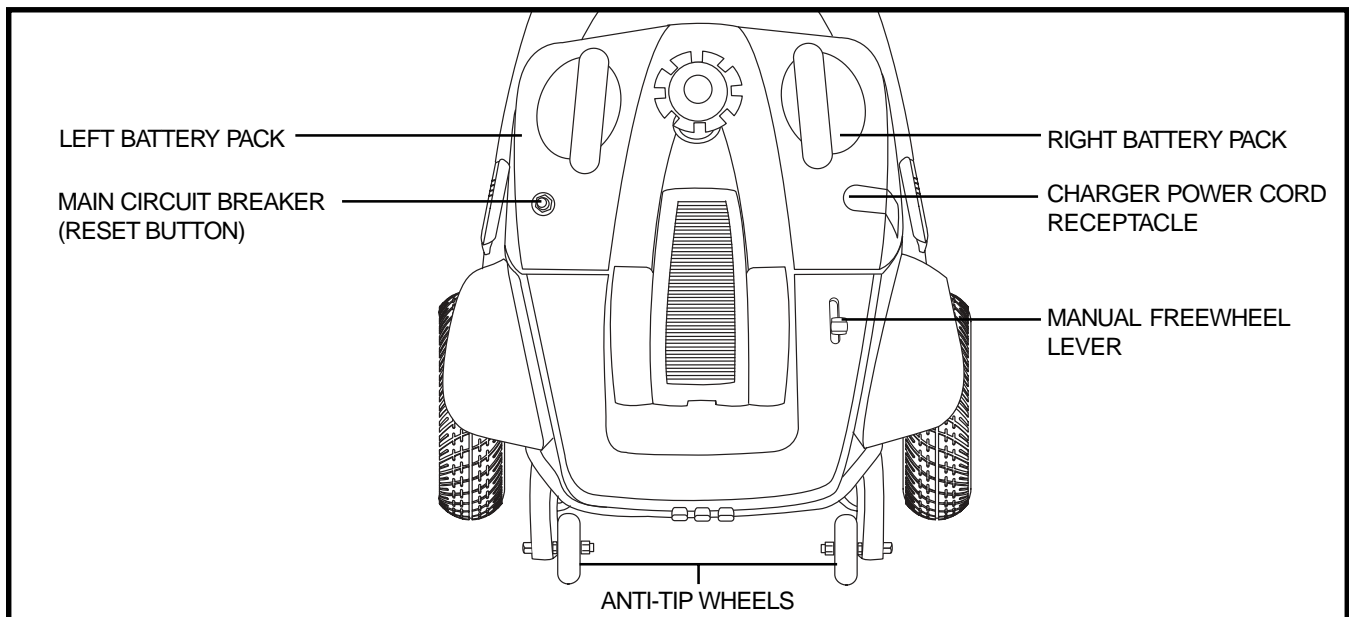

Figure 5. Rear Section

III. YOUR SCOOTER

Anti-Tip Wheels

The anti-tip wheels are an integral and important safety feature of your scooter. They are bolted to the frame at the rear of the scooter.



PROHIBITED! Do not remove the anti-tip wheels or modify your scooter in any way that is not authorized by Pride.

Battery Packs

The scooter is equipped with two easy-to-remove battery packs. The packs contain the charger power cord receptacle, the main circuit breaker (reset button), and the batteries. The batteries store electrical energy that powers your scooter. See IV. “Batteries and Charging.”

Charger Power Cord Receptacle

The charger power cord plugs into your scooter’s battery charger by means of the charger power cord receptacle.

Main Circuit Breaker (Reset Button)

When the voltage in your scooter’s batteries becomes low or the scooter is heavily strained because of excessive loads, the main circuit breaker may trip to protect the motor and electronics from damage.

- The main circuit breaker reset button pops out when the breaker trips.
- When the breaker trips, the entire electrical system of your scooter shuts down.
- Allow a minute or two for your scooter’s electronics to “rest.”
- Push in the reset button to reset the main circuit breaker.
- If the main circuit breaker trips frequently, see your authorized Pride Provider for service.

Manual Freewheel Lever

Whenever you need or want to push your scooter for short distances, you can put it in freewheel mode.

1. Remove the key from the key switch.
2. Push forward on the manual freewheel lever to disable the drive system and the brake system. This will enable you to push your scooter.
3. Pull back on the manual freewheel lever to reengage the drive and the brake systems and take your scooter out of freewheel mode.



WARNING! When your scooter is in freewheel mode, the braking system is disengaged.

- Disengage the drive motors only on a level surface.
- Ensure the key is removed from the key switch.
- Stand to one side of the scooter to engage or disengage freewheel mode. Never sit on a scooter to do this.
- After you have finished pushing your scooter, always return it to the drive mode to lock the brakes.

NOTE: *If the scooter is placed in freewheel mode (manual freewheel lever forward) while the key is in the “on” position, the scooter will not run until the manual freewheel lever is pushed backward and the key is turned to the “off” position, then back to the “on” position.*

Motor/Transaxle Assembly (Not Shown)

The motor/transaxle assembly is an electromechanical unit that converts electrical energy from your scooter’s batteries into the controlled mechanical energy that drives the scooter’s wheels.

IV. BATTERIES AND CHARGING

Your scooter is equipped with two sealed, maintenance free batteries.

- Charge the batteries prior to using your scooter for the first time.
- Keep the batteries fully charged to keep your scooter running smoothly.

READING YOUR BATTERY VOLTAGE

The battery condition meter on the tiller console uses a color code to indicate the approximate strength of your batteries. From right to left, green indicates fully charged batteries, yellow indicates a draining charge, and red indicates that an immediate recharge is necessary. See figure 6.



Figure 6. Battery Condition Meter

To check the battery strength during charging, you must first unplug the charger power cord and power up your scooter by inserting the key into the key switch and turning it to the on position.

NOTE: *To ensure the highest accuracy, the battery condition meter should be checked while operating your scooter at full speed on a level surface.*

CHARGING YOUR BATTERIES



PROHIBITED! Never use an extension cord to plug in your battery charger. Plug the charger directly into a properly wired standard electrical outlet.



PROHIBITED! Removal of the grounding prong can create an electrical hazard. If necessary, properly install an approved 3-pronged adapter to an electrical outlet having 2-pronged plug access.



PROHIBITED! Do not allow unsupervised children to play near the scooter while the batteries are charging. Pride recommends that you do not charge the batteries while the scooter is occupied.



MANDATORY! Read the battery charging instructions in this manual and in the manual supplied with the battery charger before charging the batteries.



WARNING! Explosive gases may be generated while charging the batteries. Keep the scooter and the battery charger away from sources of ignition such as flames or sparks and provide adequate ventilation when charging the batteries.

WARNING! Ensure that both ends of the charger power cord are clean and dry before plugging the charger power cord into the charger power cord receptacle or the electrical outlet.

WARNING! You must recharge your scooter's batteries with the supplied off-board charger. Do not use an automotive-type battery charger.



WARNING! Inspect the battery charger, wiring, and connectors for damage before each use. Contact your authorized Pride Provider if damage is found.

WARNING! Do not attempt to open the battery charger case. If the battery charger does not appear to be working correctly, contact your authorized Pride Provider.

WARNING! If the battery charger is equipped with cooling slots, then do not attempt to insert objects through these slots.

IV. BATTERIES AND CHARGING



WARNING! If your off-board battery charger has not been tested and approved for outdoor use, then do not expose it to adverse or extreme weather conditions. If the battery charger is exposed to adverse or extreme weather conditions, then it must be allowed to adjust to the difference in environmental conditions before use indoors. Refer to the manual supplied with the battery charger for more information.

The off-board charger supplied with your scooter is equipped with a 115/230 voltage switch. Confirm that this switch is in the proper position for your locality. If you are not sure what the voltage is in your country, contact your local electricity provider before inserting the charger power cord into your electrical outlet. If the setting is incorrect, the charger will not function properly. Slide the voltage switch to the appropriate position. See figure 7.

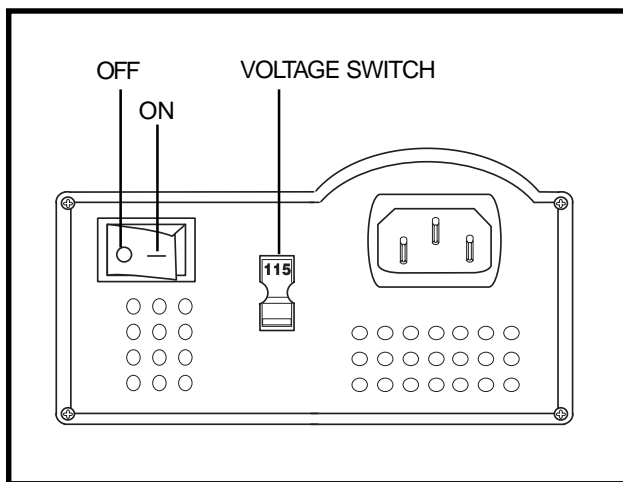

Figure 7. Charger On/Off and Voltage Switches

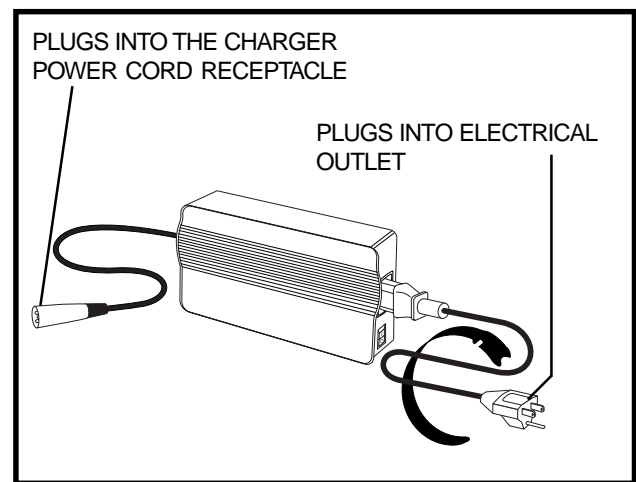

Figure 7A. Off-Board Charger

To charge the batteries with the battery packs installed on the scooter:

1. Position the rear of your scooter close to a standard electrical outlet.
2. Remove the key from the key switch.
3. Make sure that the manual freewheel lever is in the drive position.
4. Make sure that the charger's on/off switch is in the OFF position. See figure 7.
5. Plug the 3-pin charger power cord into the charger power cord receptacle. See figures 7A and 8.
6. Extend the charger power cord and plug it into the electrical outlet.
7. Turn the charger on. See figure 7. We recommend that you charge your batteries for 8 to 14 hours.
8. When the batteries are fully charged, turn the charger off and unplug the charger power cord from the electrical outlet and then from the charger power cord receptacle.
9. Replace the charger power cord receptacle cover.

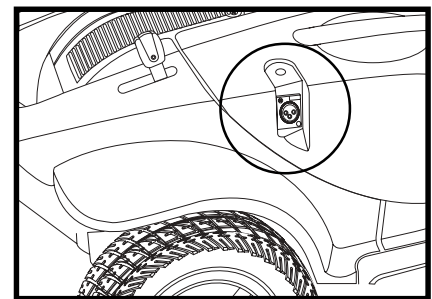

Figure 8. Charger Power Cord Receptacle

NOTE: There is a charger inhibit function on your scooter. The scooter will not run and the battery condition meter will not operate while the batteries are charging.

IV. BATTERIES AND CHARGING

To charge the batteries with the battery packs removed from the scooter:

1. Remove the battery packs from the scooter and place them on a flat, dry surface in exactly the same positions as they are on the scooter. See VII. “Disassembly and Assembly” for information on how to remove and position the battery packs.

NOTE: *The battery packs must be connected in order to charge.*

2. Follow steps 4-9 from the previous page.
3. Reinstall the battery packs onto the scooter.

FREQUENTLY ASKED QUESTIONS

How does the charger work?

When your scooter’s battery voltage is low the charger works harder, sending more electrical current to the batteries to bring up their charge. As the voltage approaches full charge, the charger sends less and less electrical current to the batteries. When the batteries are fully charged, the current sent by the charger is at nearly zero amperage. Therefore, when the charger is plugged in, it maintains the charge on your scooter’s batteries, but does not overcharge them. We do not recommend that you charge your scooter’s batteries for more than 24 consecutive hours.

What if my scooter’s batteries won’t charge?

- Ensure that both ends of the charger power cord are inserted fully.
- Ensure that both battery packs are seated into the battery wells properly.
- Ensure that the charger is turned on at the toggle switch located on the side of the off-board charger.
- Check the charger fuse located inside the right battery pack. The fuse is attached to the wire leading from the charger power cord receptacle.

How often must I charge the batteries?

Two major factors must be considered when deciding how often to charge your scooter’s batteries:

- All day scooter use on a daily basis.
- Infrequent or sporadic scooter use.

With these considerations in mind, you can determine how often and for how long you should charge your scooter’s batteries. We designed the charger so that it will not overcharge your scooter’s batteries. However, you may encounter some problems if you do not charge your batteries often enough and if you do not charge them on a regular basis. Following the guidelines below will provide safe and reliable battery operation and charging:

- If you use your scooter daily, charge its batteries as soon as you finish using it for the day. Your scooter will be ready each morning. We recommend that you charge your scooter’s batteries for 8 to 14 hours after daily use.
- If you use your scooter once a week or less, charge its batteries at least once a week for 12 to 14 hours at a time.
- Keep your scooter’s batteries fully charged.
- Avoid deeply discharging your scooter’s batteries.

IV. BATTERIES AND CHARGING

How can I get maximum range or distance per charge?

Rarely will you have ideal driving conditions—smooth, flat, hard driving surfaces with no wind or curves. Often, you will face hills, pavement cracks, uneven and loosely packed surfaces, curves, and wind, all of which affect the distance or running time per battery charge. Below are a few suggestions for obtaining the maximum range per battery charge:

- Always fully charge your scooter's batteries prior to daily use.
- Maintain but do not exceed the psi/bar/kPa air pressure rating indicated on each tire for pneumatic tires.
- Plan your route ahead to avoid as many hills, cracked, broken, or soft surfaces as possible.
- Limit your baggage weight to essential items.
- Try to maintain an even speed while your scooter is in motion.
- Avoid stop-and-go driving.

What type and size of battery should I use?

We recommend deep-cycle batteries that are sealed and maintenance free. Both AGM and Gel-Cell are deep-cycle batteries that are similar in performance. Do not use wet-cell batteries, which have removable caps.



WARNING! Corrosive chemicals are contained in batteries. Use only AGM or Gel-cell batteries to reduce the risk of leakage or explosive conditions.

NOTE: Sealed batteries are not serviceable. Do not remove the caps.

How do I change the batteries in my scooter?



MANDATORY! Battery posts, terminals, and related accessories contain lead and lead compounds. Wear goggles and gloves when handling batteries and wash hands after handling.



WARNING! Always use two batteries of the exact same type, chemistry, and amp-hour (Ah) capacity. Refer to the specifications table in this manual and in the manual supplied with the battery charger for recommended type and capacities.

WARNING! Do not mix old and new batteries. Always replace both batteries at the same time.

WARNING! Contact your authorized Pride Provider if you have any questions regarding the batteries in your scooter.



WARNING! Do not replace the batteries while the scooter is occupied.

WARNING! The batteries on your scooter should only be serviced or replaced by an authorized Pride Provider or a qualified technician.

To change the batteries in your scooter:

1. Remove the seat.
2. Remove the battery packs from the scooter. Always remove the left side battery pack first. See VII. "Disassembly and Assembly."
3. Remove the 7 screws from the underside of each pack.
4. Arrange each pack so the handle is facing up, slowly remove the cover, and situate it as shown in figure 9.
5. Disconnect the battery cables from the battery terminals by removing the nut and bolt from each terminal.

IV. BATTERIES AND CHARGING

6. Remove the old batteries.
7. Place a new battery into each battery pack.
8. Connect the red battery cable to the positive (+) battery terminal on each battery.
9. Connect the black battery cable to the negative (-) battery terminal on each battery.
10. Replace each battery pack cover.
11. Reinstall the 7 screws to each pack and tighten.
12. Reinstall the battery packs onto the scooter and close the battery locks. Always reinstall the right side battery pack first.
13. Reinstall the seat.

NOTE: *If you encounter a damaged or cracked battery, immediately enclose it in a plastic bag. Contact your local waste disposal agency and/or your authorized Pride Provider for instructions on disposal and battery recycling, which is our recommended course of action.*

Why do my new batteries seem weak?

Deep-cycle batteries employ a different chemical technology than that used in car batteries, nickel-cadmium batteries (nicads), and other common battery types. Deep-cycle batteries are specifically designed to provide power, drain down their charge, and then accept a relatively quick recharge.

We work closely with our battery manufacturer to provide batteries that best suit your scooter's specific electrical demands. Fresh batteries arrive daily at Pride and are shipped fully charged to our customers. During shipping, the batteries may encounter temperature extremes that can influence their initial performance. Heat diminishes the charge on the battery; cold slows the available power and extends the time needed to recharge the battery.

It may take a few days for the temperature of your scooter's batteries to stabilize and adjust to their new room or ambient temperature. More importantly, it takes a few charging cycles (partial draining followed by recharging) to establish the critical chemical balance that is essential to a deep-cycle battery's peak performance and long life.

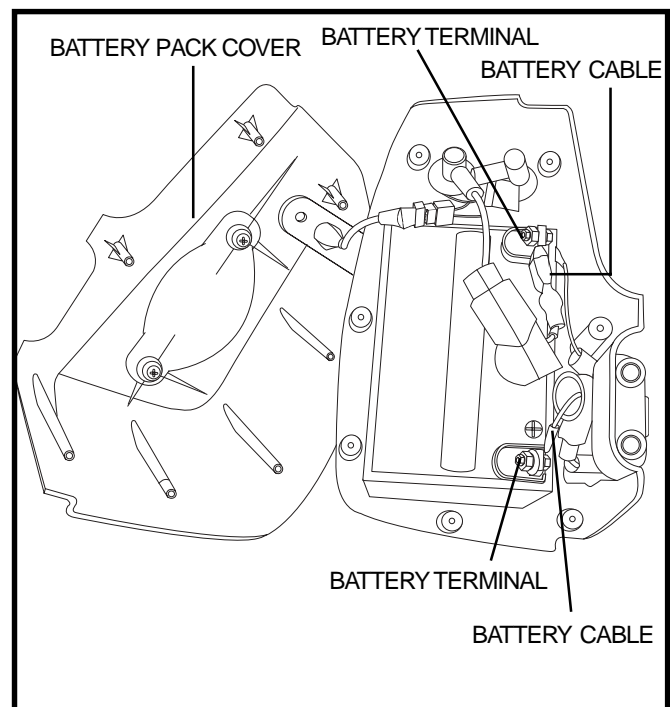

Figure 9. Battery Replacement

IV. BATTERIES AND CHARGING

Follow these steps to properly break in your scooter's new batteries for maximum efficiency and service life.

1. Fully recharge any new battery prior to its initial use. This charging cycle brings the battery up to about 88% of its peak performance level.
2. Operate your new scooter in familiar and safe areas. Drive slowly at first, and do not travel too far from your home or familiar surroundings until you have become accustomed to your scooter's controls and have properly broken in your scooter's batteries.
3. Fully recharge the batteries. They should be at over 90% of their peak performance level.
4. Operate your scooter again.
5. Fully recharge the batteries again.
6. After four or five charging cycles, the batteries are able to receive a charge of 100% of their peak performance level and are able to last for an extended period of time.

What about public transportation?

If you intend to use public transportation with your scooter, you must contact the transportation provider in advance to determine their specific requirements.

V. OPERATION

BEFORE GETTING ONTO YOUR SCOOTER

- Have you fully charged the batteries? See IV. “Batteries and Charging.”
- Is the manual freewheel lever in the drive (rearward) position? Never leave the manual freewheel lever pushed forward unless you are manually pushing your scooter.
- Is the tiller lock knob in the unlocked position and can you turn the tiller from side to side freely?

GETTING ONTO YOUR SCOOTER



WARNING! Before getting onto your scooter always check that the tiller lock knob is in the unlocked position. Attempting to ride your scooter with the tiller lock knob in the locked position can result in personal injury.

WARNING! Never attempt to get onto or off of your scooter without first removing the key from the key switch. This will prevent the scooter from moving if accidental throttle control lever contact is made.

1. Make certain that the key is removed from the key switch.
2. Stand at the side of your scooter.
3. Disengage the seat rotation lever and rotate the seat until it is facing you.
4. Make certain that the seat is fixed securely in position.
5. Position yourself comfortably and securely in the seat.
6. Disengage the seat rotation lever and rotate the seat until you are facing forward.
7. Make certain that the seat is fixed securely in position.
8. Make certain that your feet are safely on the floorboard.

PRE-RIDE ADJUSTMENTS AND CHECKS

- Is the seat at the proper height? See VI. “Comfort Adjustments.”
- Is the seat fixed securely in place?
- Is the tiller at a comfortable setting and locked securely in place? See VI. “Comfort Adjustments.”
- Is the key fully inserted into the key switch?
- Does the scooter’s horn work properly?
- Is your proposed path clear of people, pets, and obstacles?
- Have you planned your route to avoid adverse terrain and as many inclines as possible?

OPERATING YOUR SCOOTER



WARNING! The following can adversely affect steering and stability while operating your scooter, resulting in a loss of control, tipping, and/or personal injury:

- Holding onto or attaching a leash to walk your pet
- Carrying passengers (including pets)
- Hanging any article from the tiller
- Towing or being pushed by another motorized vehicle

V. OPERATION

Keep both hands on the tiller and your feet on the floorboard at all times while operating your scooter. This driving position gives you the most control over your vehicle.

- Set the speed adjustment dial to your desired speed.
- Press your thumb against the appropriate side of the throttle control lever.
- The electromechanical disc park brake automatically disengages and the scooter accelerates smoothly to the speed you preselected with the speed adjustment dial.
- Pull on the left handgrip to steer your scooter to the left.
- Pull on the right handgrip to steer your scooter to the right.
- Move the tiller to the center position to drive straight ahead.
- To stop, slowly release the throttle control lever. The electronic brakes will automatically engage, bringing your scooter to a stop.

NOTE: Your scooter's reverse speed is slower than that of the forward speed you preset with the speed adjustment dial.

GETTING OFF OF YOUR SCOOTER

1. Bring your scooter to a complete stop.
2. Power down your scooter and remove the key from the key switch.
3. Disengage the seat rotation lever and rotate the seat until you are facing toward the side of your scooter.
4. Make certain that the seat is fixed securely in position.
5. Carefully and safely get out of the seat and stand to the side of your scooter.
6. You can leave the seat facing to the side to facilitate boarding your scooter next time.

POWER DOWN TIMER FEATURE

Your scooter is equipped with an energy saving automatic power down timer feature designed to preserve your scooter's battery life. If you mistakenly leave the key in the key switch but do not use your scooter for approximately 20 minutes, the scooter's controller shuts down automatically. Although the controller is shut down, power will still be supplied to the scooter's lighting system.

If the power down timer feature takes effect, perform the following steps to resume normal operation:

1. Remove the key from the key switch.
2. Reinsert the key and power up your scooter.

VI. COMFORT ADJUSTMENTS

TILLER ANGLE ADJUSTMENT



WARNING! Remove the key from the key switch before adjusting the tiller or the seat. Never attempt to adjust the tiller or the seat while the scooter is in motion.

Your scooter is equipped with an adjustable pivoting tiller.

1. While supporting the tiller, turn the tiller adjustment knob counterclockwise to loosen the tiller. See figure 10.
2. Move the tiller to a comfortable position.
3. Turn the tiller angle adjustment knob clockwise to secure the tiller in position.

NOTE: In order to fully lower the tiller, you must first completely remove the seat and both battery packs. See VII. “Disassembly and Assembly.”

SEAT ROTATION ADJUSTMENT

The seat rotation lever secures the seat in one of four positions.

1. Pull up on the seat rotation lever to disengage the seat. See figure 11.
2. Rotate the seat to the desired position.
3. Release the seat rotation lever to secure the seat in place.

ARMREST WIDTH ADJUSTMENT

The armrest width can be adjusted inward or outward.

1. Loosen the armrest adjustment knobs at the back of the seat frame. See figure 11.
2. Slide the armrests in or out to the desired width.
3. Tighten the armrest adjustment knobs.

NOTE: Pivot the armrests upward to aid in getting onto and off of your scooter.

FRONT-TO-BACK SEAT ADJUSTMENT

You can reposition the scooter’s seat forward or rearward to one of three settings to adjust the distance between the seat and the tiller.

1. Remove the seat from your scooter. Refer to VII. “Disassembly and Assembly.”
2. Remove the four bolts that fasten the seat to the seat platform. See figure 11.
3. Align the seat platform with the desired set of holes on the seat.
4. Replace and tighten the four bolts securely.

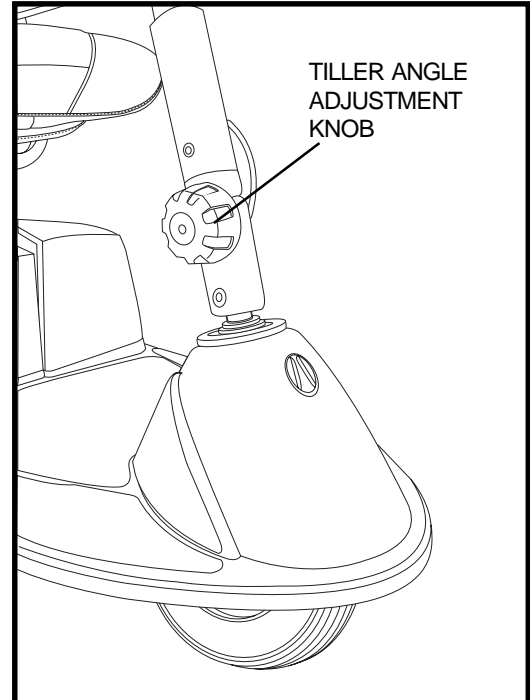

Figure 10. Tiller Angle Adjustment Knob

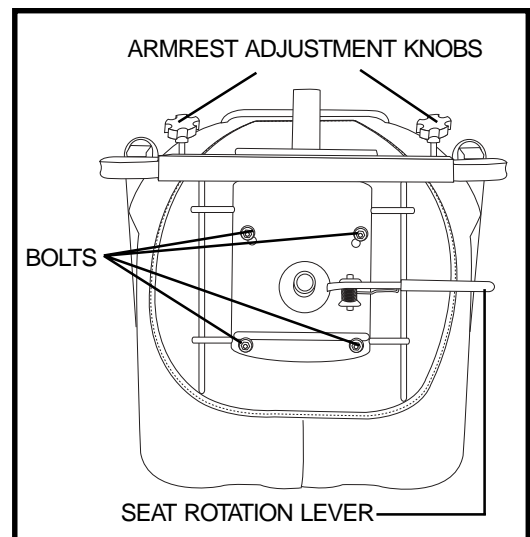

Figure 11. Seat Adjustments

VI. COMFORT ADJUSTMENTS

SEAT HEIGHT ADJUSTMENT

The seat can be repositioned to one of three different heights. See figure 12.

1. Remove the seat from your scooter. See VII. “Disassembly and Assembly.”
2. Use the attached ring to pull and remove the detent pin from the lower seat post.
3. Raise or lower the upper seat post to the desired seat height.
4. While holding the upper seat post at that height, match up the adjustment holes in the upper and lower seat posts.
5. Fully insert the detent pin.
6. Replace the seat.

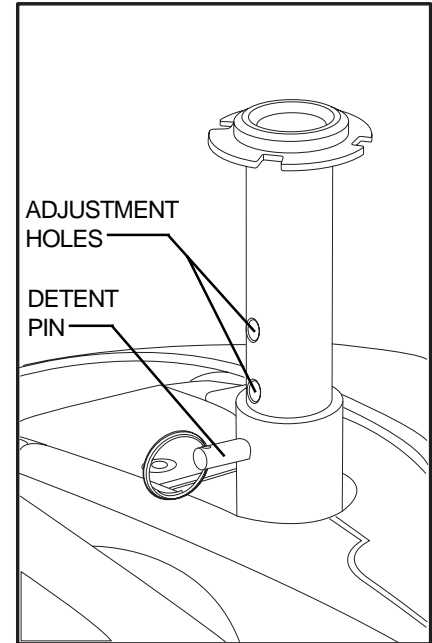

Figure 12. Seat Height Adjustment

VII. DISASSEMBLY AND ASSEMBLY

DISASSEMBLY

You can disassemble the scooter into seven pieces: the seat, the front section, the rear section, the rear shroud, the basket, and the batteries. See figure 13. No tools are required to disassemble or assemble your scooter, but keep in mind that the disassembled sections of the scooter take up more floor space than the assembled unit. Always disassemble or assemble your scooter on a level, dry surface with sufficient room for you to work and move around your scooter—about 5 feet (1.5 meters) in all directions. Remember that some scooter components are heavy and you may need assistance when lifting them.



WARNING! Do not lift beyond your physical capability. Ask for assistance when necessary while disassembling or assembling your scooter.

1. Remove the key and ensure that the manual free-wheel lever is in the drive position.
2. Lock the tiller in place by positioning it forward, then pushing the tiller lock knob inward and turning it clockwise 90 degrees. See figure 14.
3. Remove the seat by pulling up on the seat rotation lever, rotating the seat one-eighth of a turn, and lifting the seat up and off of the scooter.
4. Disengage the left battery pack lock by pulling it outward from the scooter. See figure 15.
5. Remove the left battery pack by lifting it straight up and away from the scooter. See figure 15.
6. Repeat steps 4 and 5 for the right battery pack.
7. Unplug the front-to-rear harness. See figure 16.

NOTE: When *DISASSEMBLING* the scooter, always remove the *LEFT* battery pack first. When *ASSEMBLING* the scooter, always install the *RIGHT* battery pack first.

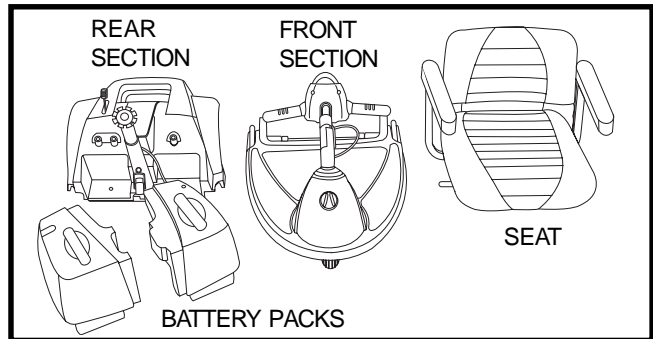

Figure 13. Scooter Components

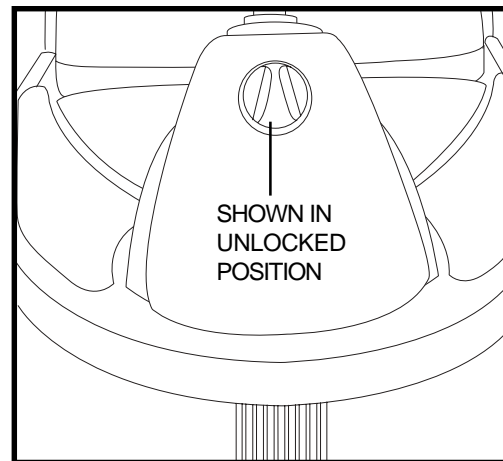

Figure 14. Tiller Lock Knob

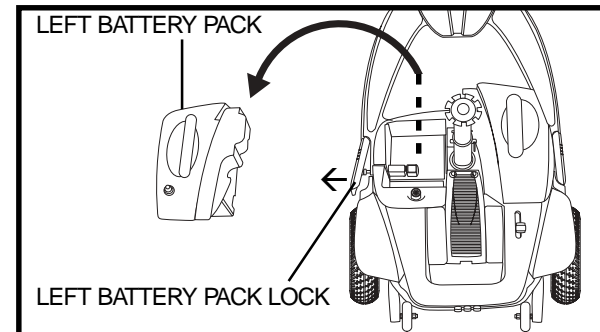

Figure 15. Battery Pack Removal/Installation

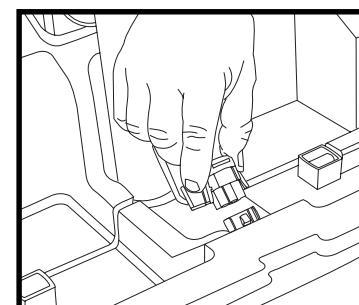

Figure 16. Front-To-Rear Harness

VII. DISASSEMBLY AND ASSEMBLY

Toggle Latch Release

1. Push in the toggle latch release button while pulling back the toggle latch. See figures 17 and 17A.
2. Secure the toggle latch buckle over the top of the toggle latch. See figure 17B.
3. Grab the hand grip on the tiller, loosen the tiller adjustment knob, and gently lower the tiller down to the center of the scooter floorboard.
4. Fully tighten the tiller adjustment knob.

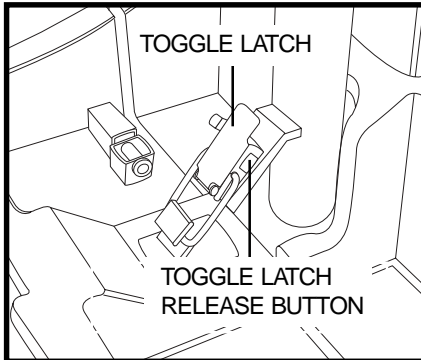

Figure 17. Toggle Latch (Latched)

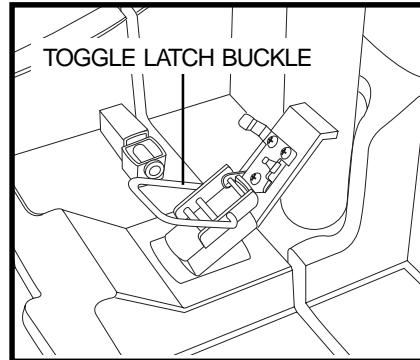

Figure 17A. Toggle Latch (Unlatched)

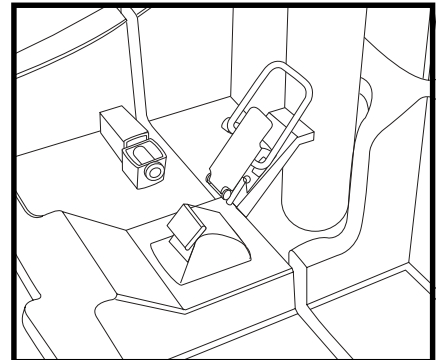

Figure 17B. Toggle Latch (Secured For Disassembly)

Frame Separation

1. Push back on the seat post to pivot the scooter's rear section rearwards until it is standing vertically on its rear bumper. See figure 18.
2. Lift the front section up until the rear pegs are no longer in the locking brackets. See figure 19.
3. Carefully move the front section away from the rear section.

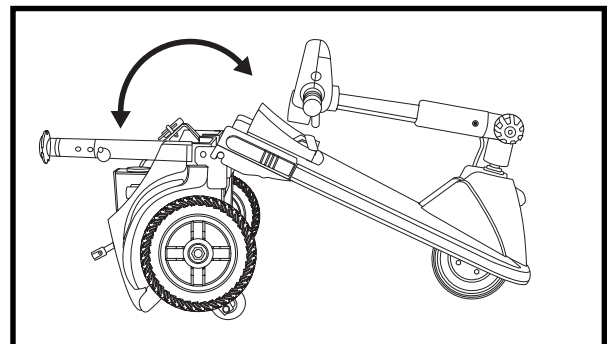

Figure 18. Frame Positioning

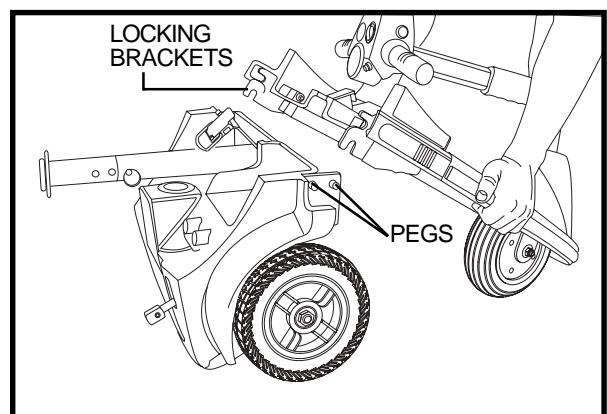

Figure 19. Frame Separation

VII. DISASSEMBLY AND ASSEMBLY

ASSEMBLY

1. Position the front and rear sections of your scooter. See figure 19.
2. Align the locking brackets of the front section with the corresponding pegs on the front of the rear section.



WARNING! Position the front-to-rear harness so it will not become pinched between the frame halves when pivoting the rear section forward.

3. Holding the seat post, slowly pivot the rear section forward until the locking brackets are fully connected onto the rear pegs. See figures 18 and 19.
4. Raise the tiller.
5. Secure the toggle latch. See figure 17B.
 - Lower the toggle latch buckle.
 - Push back on the toggle latch so it locks into place.
6. Connect the front-to-rear harness.
7. Reinstall the battery packs and engage both battery pack locks. **Always replace the right battery pack first.**
8. Replace the seat.
9. Unlock the tiller by rotating the tiller lock knob 90 degrees counterclockwise.



WARNING! Before getting onto your scooter always check that the tiller lock knob is in the unlocked position. Attempting to ride your scooter with the tiller lock knob in the locked position can result in personal injury.

VIII. BASIC TROUBLESHOOTING

Any electromechanical device occasionally requires some troubleshooting. However, most of the problems that may arise can usually be solved with a bit of thought and common sense. Many of these problems occur because the batteries are not fully charged or because the batteries are worn down and can no longer hold a charge.

DIAGNOSTIC FLASH CODES

The diagnostic flash codes for your scooter are designed to help you perform basic troubleshooting quickly and easily. A diagnostic flash code will flash from the status LED in the event one of the conditions listed below develops.

NOTE: *Your scooter will not run unless the flash code condition is resolved and the scooter has been turned off, then turned back on.*

FLASH CODE	CONDITION	SOLUTION
■ ■ (2)	Battery voltage is too low to operate the scooter.	Charge fully until charger and any meters indicate completion.
■ ■ ■ (3)	Battery voltage is too high to operate the scooter.	Contact your authorized Pride Provider for assistance.
■ ■ ■ ■ ■ (5)	Solenoid brake trip. The manual freewheel lever may be in the freewheel position.	Remove the key, then push the manual freewheel lever to the drive position, restart your scooter.
■ ■ ■ ■ ■ ■ (6)	Throttle trip. The throttle control lever may have been depressed while inserting the key.	Release the throttle control lever completely, then reinsert the key.
■ ■ ■ ■ ■ ■ ■ (7)	Throttle trip. Throttle potentiometer fault or speed potentiometer fault.	Contact your authorized Pride Provider for assistance.
■ ■ ■ ■ ■ ■ ■ ■ (8)	The scooter's motor is disconnected.	Contact your authorized Pride Provider for assistance.
■ ■ ■ ■ ■ ■ ■ ■ ■ (9)	Possible controller trip. You may be attempting to install the battery pack while the key is inserted or the motor controller may be in overheat protective mode.	Shut down your scooter for a minimum of several minutes to allow the controller to cool. Or, try reinserting the key into the key switch.

What if all the systems on my scooter seem to be “dead”?

- Make certain that the key is in the “on” position.
- Check that the batteries are fully charged.
- Push in the main circuit breaker reset button. See III. “Your Scooter.”
- Make certain that both battery packs are installed and seated properly.
- Make sure that the front-to-rear harness is firmly connected. See VII. “Disassembly and Assembly.”
- Be sure the power down timer feature hasn’t been activated. See V. “Operation.”

What if my scooter does not move when I press the throttle control lever?

- When the manual freewheel lever is pushed forward, the brakes are disengaged and all power to the motor/transaxle assembly is cut.
- Push rearward on the manual freewheel lever, turn the scooter off, and then turn the scooter on to return to normal scooter operation.

VIII. BASIC TROUBLESHOOTING

What if the main circuit breaker repeatedly trips?

- If the main circuit breaker repeatedly trips, see your authorized Pride Provider for service.
- Charge the batteries more frequently. See IV. “Batteries and Charging.”
- If the problem continues, have both batteries load tested by your authorized Pride Provider.
- You may also perform the load test yourself. Battery load testers are available at most automotive parts stores. Follow the directions supplied with the load tester.
- See IV. “Batteries and Charging” or “Appendix I - Specifications” for information about your scooter’s battery type.

What if the battery condition meter dips way down and the motor surges or hesitates when I engage the scooter’s throttle control lever?

- Fully charge your scooter’s batteries. See IV. “Batteries and Charging.”
- Have your authorized Pride Provider load test each battery.
- Or, see the previous troubleshooting question for load testing the batteries yourself.

If you experience any problems with your scooter that you are not able to solve, immediately contact your authorized Pride Provider for information, maintenance, and service.

IX. CARE AND MAINTENANCE

Your scooter requires a minimal amount of care and maintenance. If you do not feel confident in your ability to perform the maintenance listed below, you may schedule inspection and maintenance at your authorized Pride Provider. The following areas require periodic inspection and/or care and maintenance.

TIRE PRESSURE

- If equipped with pneumatic tires, always maintain the psi/bar/kPa air pressure rating indicated on each tire.



WARNING! It is important that the psi/bar/kPa air pressure rating indicated on each tire be maintained in pneumatic tires at all times. Do not underinflate or overinflate your tires. Low pressure may result in loss of control, and overinflated tires may burst. Failure to maintain the psi/bar/kPa air pressure rating indicated on the tires at all times may result in tire and/or wheel failure.

- Regularly inspect your scooter's tires for signs of wear.

WHEEL REPLACEMENT

If your scooter is equipped with pneumatic tires and you have a flat tire, you can have the tube replaced. If your scooter is equipped with a solid tire insert, either the solid insert or the entire wheel must be replaced depending on the model. Contact your authorized Pride Provider for information regarding replacement wheels for your scooter.

WARNING! Wheels on your scooter should only be serviced/replaced by an authorized Pride Provider or qualified technician.



WARNING! Completely deflate pneumatic tires before dismantling the rim or attempting repair.

WARNING! When changing a tire, remove only the center lug nut, then remove the tire. If any further disassembly is required, deflate the tire completely or it may explode.

EXTERIOR SURFACES

Bumpers and tires can benefit from an occasional application of a rubber or vinyl conditioner.



WARNING! Do not use a rubber or vinyl conditioner on the scooter's vinyl seat or tire tread, as this may cause them to become dangerously slippery.

CLEANING AND DISINFECTION

- Use a damp cloth and mild, non-abrasive cleanser to clean the plastic and metal parts of your scooter. Avoid using products that may scratch the surface of your scooter.
- If necessary, clean your product with an approved disinfectant. Make sure the disinfectant is safe for use on your product before application.



WARNING! Follow all safety instructions for the proper use of the disinfectant before applying it to your product. Failure to comply may result in skin irritation or premature deterioration of upholstery and/or scooter finishes.

BATTERY TERMINAL CONNECTIONS

- Make certain that the terminal connections remain tight and uncorroded.
- The batteries must sit flat in the battery wells.

IX. CARE AND MAINTENANCE

WIRING HARNESSES

- Regularly check all wiring connections.
- Regularly check all wiring insulation, including the charger power cord, for wear or damage.
- Have your authorized Pride Provider repair or replace any damaged connector, connection, or insulation that you find before using your scooter again.



PROHIBITED! Even though the scooter has passed the necessary testing requirements for ingress of liquids, you should keep electrical connections away from sources of dampness, including direct exposure to water or bodily fluids and incontinence. Check electrical components frequently for signs of corrosion and replace as necessary.

ABS PLASTIC SHROUDS

- The front tiller shroud, front shroud, and the rear shroud are formed from durable ABS plastic and are coated with an advanced formula urethane paint.
- A light application of car wax will help the shrouds retain their high gloss.

AXLE BEARINGS AND THE MOTOR/TRANSAXLE ASSEMBLY

These items are all prelubricated, sealed, and require no subsequent lubrication.

MOTOR BRUSHES

The motor brushes are housed inside of the motor/transaxle assembly. They should be inspected periodically for wear by your authorized Pride Provider.

CONSOLE AND REAR ELECTRONICS

- Keep these areas free of moisture.
- Allow these areas to dry thoroughly if they have been exposed to moisture before operating your scooter again.

FUSE REPLACEMENT

In the event a fuse should cease to work:

1. Remove the fuse by pulling it out of its slot.
2. Examine the fuse to be sure it is blown. See figures 20 and 20A.
3. Insert a new fuse of the proper rating.



WARNING! The replacement fuse must exactly match the rating of the new fuse. Failure to use properly rated fuses may cause damage to the electrical system.

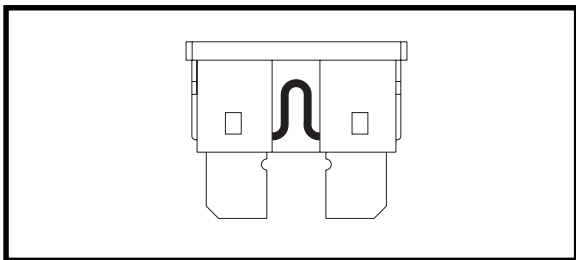

Figure 20. Working Fuse

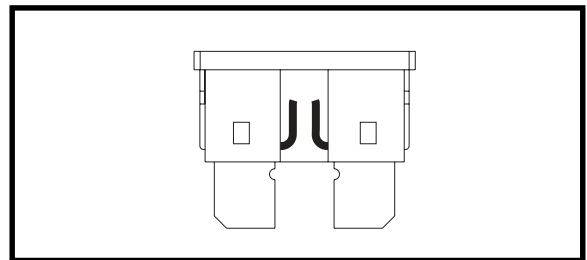

Figure 20A. Blown Fuse (Replace)

IX. CARE AND MAINTENANCE

LIGHT BULB REPLACEMENT

The scooter's light bulbs are easily replaceable. Do not use regular automotive-type 12-volt light bulbs; your scooter is equipped with a 24-volt electrical system. Replacement light bulbs can be purchased from your authorized Pride Provider.

NOTE: Use only 24-volt light bulbs.

1. Remove the light cover.
2. Gently remove the bulb by pulling it straight out.
3. Insert a new bulb of the same wattage.
4. Replace the light cover.

NYLON LOCK NUT REPLACEMENT

Any nylon insert lock nut removed during the periodic maintenance, assembly, or disassembly of the scooter must be replaced with a new nut. Nylon insert lock nuts should not be reused as it may cause damage to the nylon insert, resulting in a less secure fit. Replacement nylon insert lock nuts are available at local hardware stores or through your authorized Pride Provider.

STORING YOUR SCOOTER

If you plan on not using your scooter for an extended period of time, it is best to:

- Fully charge its batteries prior to storage.
- Disconnect the batteries from the scooter.
- Store your scooter in a warm, dry environment.
- Avoid storing your scooter where it will be exposed to temperature extremes.



WARNING! Always protect batteries from freezing temperatures and never charge a frozen battery. Charging a frozen battery can result in damage to the battery.

Batteries that are regularly and deeply discharged, infrequently charged, stored in extreme temperatures, or stored without a full charge may be permanently damaged, causing unreliable performance and limited service life. It is recommended that you charge the scooter batteries periodically throughout periods of prolonged storage to ensure proper performance.

You may wish to place several boards under the frame of your scooter to raise it off of the ground during periods of prolonged storage. This takes the weight off the tires and reduces the possibility of flat spots developing on the areas of the tires contacting the ground.

DISPOSAL OF YOUR SCOOTER

Your scooter must be disposed of according to applicable local and national statutory regulations. Contact your local waste disposal agency or authorized Pride Provider for information on proper disposal of packaging, metal frame components, plastic components, electronics, and batteries.

X . W A R R A N T Y

THREE-YEAR LIMITED WARRANTY

For three (3) years from the date of purchase, Pride will repair or replace at our option to the original purchaser, free of charge, any of the following parts found upon examination by an authorized representative of Pride to be defective in material and/or workmanship:

Structural Frame Components, Including:

- Main Frame
- Fork
- Seat Post
- Tiller Frame

THREE-YEAR PRORATA WARRANTY

Three-year prorata drivetrain warranty, including:

- Transaxle
- Motor Brake (electronic function ONLY)
- Brake

These components will be prorated on the following schedule:

- First year: 100% replacement of parts cost
- Second year: 67% replacement of parts cost
- Third year: 50% replacement of parts cost

NOTE: If there is an increase in the operational noise level in the transaxle, the warranty does not apply. An increase in operational noise level usually occurs due to abusive and excessive strain on the scooter.

ONE-YEAR LIMITED WARRANTY

For one (1) year from the date of purchase, Pride will repair or replace at our option to the original purchaser, free of charge, any of the following parts found upon examination by an authorized representative of Pride to be defective in material and/or workmanship:

- Bearings
- Bushings
- Rubber Components
- Plastic components (except body)

Also, electronic assemblies including:

- Electronic Controllers
- Chargers
- Harnesses
- Any other electrical subassembly

SIX-MONTH WARRANTY

The battery is covered by a separate six-month warranty, provided by the battery manufacturer. The batteries are not warranted by Pride.

RECONDITIONED UNITS WARRANTY

All reconditioned units are covered by a six-month warranty from Pride effective from the date of purchase.

WARRANTY EXCLUSIONS

This warranty does not extend to those items which may require replacement due to normal wear and tear.

- ABS Plastic shrouds
- Motor brushes
- Upholstery and seating
- Brake Pads
- Tires and tubes
- Fuses/Bulbs

X . W A R R A N T Y

- Circumstances beyond the control of Pride
- Labor, service calls, shipping, and other charges incurred for repair of the product, unless specifically authorized, IN ADVANCE, by Pride Mobility Products Corporation
- Repairs and/or modifications made to any part without specific consent from Pride

Exclusions also include components with damage caused by:

- Contamination
- Abuse, misuse, accident, or negligence
- Battery fluid spillage or leakage
- Commercial use, or use other than normal
- Improper operation, maintenance, or storage

NOTE: Gradual deterioration in performance because the battery has been left in a discharged state, left in cold conditions for an extended period of time, or worn out through heavy use is not covered.

SERVICE CHECKS AND WARRANTY SERVICE

Warranty service must be performed by an authorized Pride Provider. Do not return faulty parts to Pride without prior written authorization. All transportation costs and shipping damage incurred while submitting parts for repair or replacement are the responsibility of the purchaser. Please contact your authorized Pride Provider for information on the current cost associated with a service visit.

There is no other express warranty.

IMPLIED WARRANTIES

Implied warranties, including those of merchantability and fitness for a particular purpose, are limited to one (1) year from the date of original purchase and to the extent permitted by law. Any and all implied warranties are excluded. This is the exclusive remedy. Liabilities for consequential damages under any and all warranties are excluded.

Some states do not allow limitations on how long an implied warranty lasts or do not allow the exclusion of limitation of incidental or consequential damages. So, the above limitation or exclusion may not apply to you.

APPENDIX I - SPECIFICATIONS

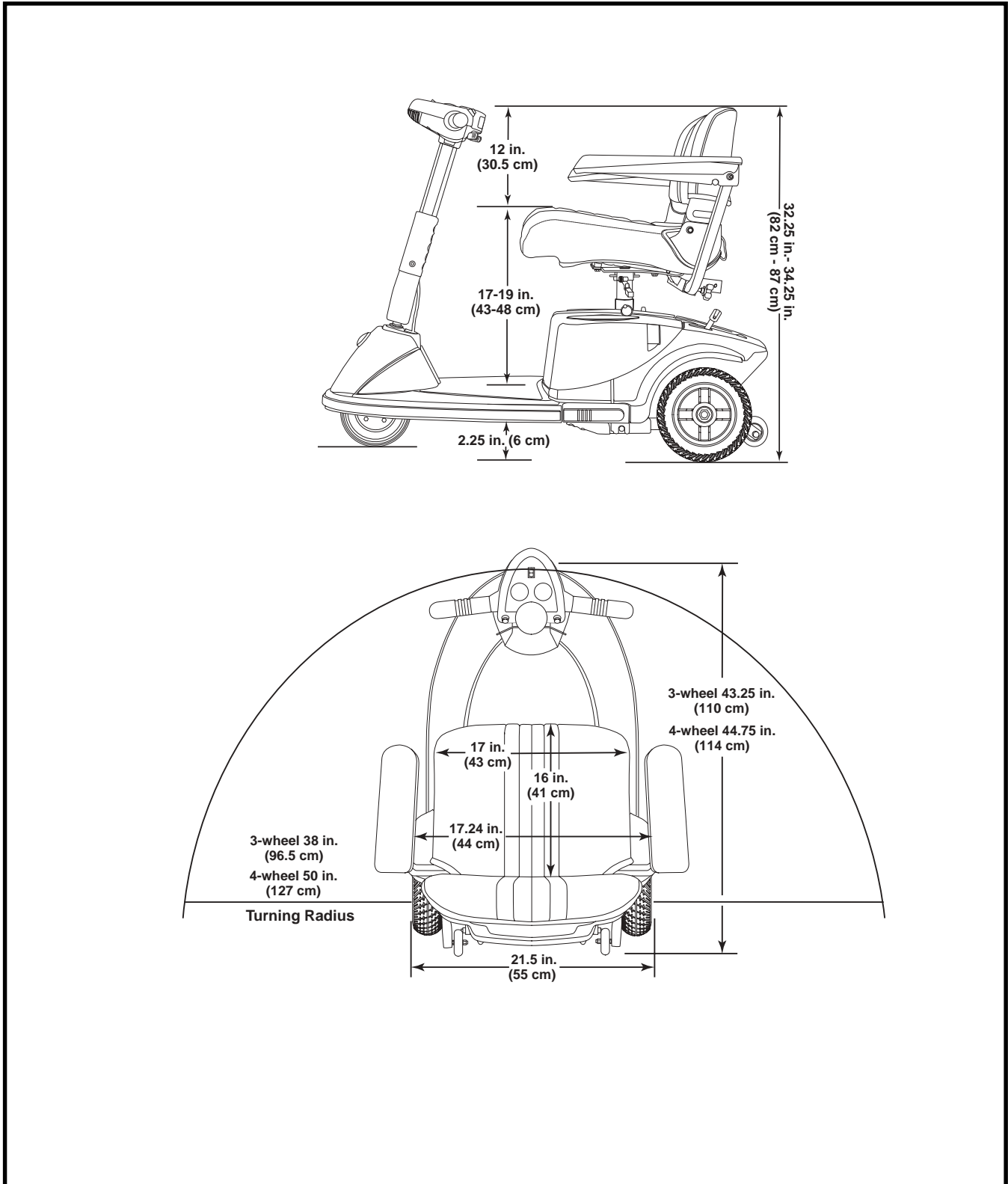

Figure 21. Scooter Dimensions

APPENDIX I - SPECIFICATIONS

Model Numbers	3-wheel: SC63; 4-wheel: SC64
Available Colors	Revo Red, Revo Blue
Overall Length ²	3-wheel: 43.25 in. (110 cm) 4-wheel: 44.75 in. (114 cm)
Overall Width ²	21.5 in. (55 cm)
Total Weight Including Battery Packs	3-wheel: 168.5 lbs. (76 kg) 4-wheel: 187 lbs. (85 kg)
Total Weight Without Battery Packs	3-wheel: 106.5 lbs. (48 kg) 4-wheel: 125 lbs. (57 kg)
Heaviest Piece When Disassembled	3-wheel: rear section (48 lbs. / 22 kg) 4-wheel: front section (51.5 lbs. / 23 kg)
Turning Radius ²	3-wheel: 38 in. (96.5 cm) 4-wheel: 50 in. (127 cm)
Speed (maximum) ¹	Variable up to 4.5 mph (7.24 km/h)
Range Per Charge ¹	Up to 20 miles (32 km) with 35 Ah batteries
Ground Clearance ²	2.25 in. (6 cm)
Weight Capacity	300 lbs. (136 kg) Maximum
Standard Seating	Type: Foldable molded plastic Material: Black vinyl with Charcoal fabric center Dimensions: 17 in. width (43 cm) 16 in. depth (41 cm) 12 in. height (30.5 cm)
Drive System	Rear-wheel drive, sealed transaxle, with 24 volt, DC motor
Dual Braking System	Electronic, regenerative, and electromechanical
Wheels	3-wheel front: molded plastic 3-wheel rear: aluminum mags 4-wheel front: aluminum mags 4-wheel rear: aluminum mags
Tires	Type: solid, flat-free Front: 2 in. x 8 in. (5 cm x 20 cm) Rear: 3 in. x 9 in. (7.6 x 23 cm)
Battery Requirements	Type: (2) 12-volt, deep cycle Size: U1 (35 Ah) Battery pack weight: 31 lbs. (14 kg) each
Battery Charger	Off-board charger

¹ Varies with user weight, terrain type, battery amp-hour (Ah), battery charge, battery condition, and tire condition. This specification can be subject to a variance of (+ or -) 10%.

² Due to manufacturing tolerances and continual product improvement, this specification can be subject to a variance of (+ or -) 3 %.

³ AGM or Gel-Cell type required. See V. “Batteries and Charging.”

NOTE: All specifications subject to change without notice.

NOTES

NOTES

NOTES



Pride
Mobility Products Corp.

*182 Susquehanna Ave.
Exeter, PA 18643*

www.pridemobility.com