

Legend

Owner's Manual

ATTENTION:
Read everything
in this manual
before operating
your Scooter



The Ultimate In Style & Performance[®]

Pride
Mobility Products Corp.

*Exeter, PA
St. Catharines, ON*

1-800-800-8586

www.pridemobility.com

SAFETY GUIDELINES

Please read and follow all instructions in this owner's manual before attempting to operate your Scooter for the first time. If there is anything in this manual you do not understand, or if you require additional assistance for set-up, contact your authorized Pride provider.

Using your Pride product safely depends upon your diligence in following the warnings, cautions, and instructions in this owner's manual. Using your Pride product safely also depends upon your own good judgement and/or common sense, as well as that of your provider, caregiver, and/or healthcare professional. Pride is not responsible for injuries and/or damage resulting from any person's failure to follow the warnings, cautions, and instructions in this owner's manual. Pride is not responsible for injuries and/or damage resulting from any person's failure to exercise good judgement and/or common sense.

The symbols below are used throughout this owner's manual to identify warnings and cautions. It is very important for you to read and understand them completely.



WARNING! Failure to heed the warnings in this owner's manual may result in personal injury.



CAUTION! Failure to heed the cautions in this owner's manual may result in damage to your Scooter.

CONTENTS

I. INTRODUCTION	4
II. SAFETY	6
III. EMI/RFI	15
IV. SPECIFICATIONS	17
V. YOUR LEGEND	19
VI. BATTERIES AND CHARGING	23
VII. OPERATION	28
VIII.COMFORT ADJUSTMENTS	30
IX. DISASSEMBLY AND ASSEMBLY	33
X. OPTIONAL ACCESSORIES	36
XI. BASIC TROUBLESHOOTING	37
XII. CARE AND MAINTENANCE	38
XIII. WARRANTY	39

I . I N T R O D U C T I O N

Welcome to Pride Mobility Products Corporation (Pride). Congratulations on the purchase of your new Pride Scooter. Your Scooter design combines the most advanced state-of-the-art components with modern, attractive styling. We are certain that the design features and trouble-free operation will add convenience to your daily living and ensure complete satisfaction.

At Pride, your safety is important to us. **Please read and follow all of the instructions in this manual before you attempt to operate your Scooter for the first time.** These instructions were produced for your benefit. Your understanding of these instructions is essential for the safe operation of your new Pride Scooter.

Pride is not liable for damage to property or personal injury arising out of unsafe use of a Pride Scooter. Pride is also not liable for any property damage or personal injury arising out of the failure of any person and or/user to following the instructions and recommendations set forth in this manual or any other instructions or recommendations contained in other Scooter related literature issued by Pride or contained on the Pride Scooter itself.

This owner's manual is compiled from the latest specifications and product information available at the time of publication. We reserve the right to make changes as they become necessary. Any changes to our products may cause slight variations between the illustrations and explanations in this manual and the product you have purchased.

If you experience any problems with your Scooter that your are unable to solve, or if you do not feel capable of safely following any of the instructions and/or recommendations as contained in this manual, please contact your authorized Pride provider for assistance.

Once you understand how to operate and take care of your Scooter, we are certain that it will give you years of trouble-free service and enjoyment.

Information Exchange

We want to hear your questions, comments, and suggestions about this manual. We would also like to hear about the safety and reliability of your new Pride Scooter, and about the service you received from your authorized Pride provider.

Please notify us of any change of address, so we can keep you apprised of important information about safety, new products, and new options that can increase your ability to use and enjoy your Pride Scooter. Please feel free to write us at the address below:

Pride Mobility Products Corporation
Attn: Technical Service Department
182 Susquehanna Avenue
Exeter, PA 18643-2694

I . I N T R O D U C T I O N

Pride Owners Club

As an owner of a Pride product, you are invited to register your product's warranty and enroll in the Pride Owners Club. You may do so by filling out and returning your enclosed registration card or by visiting Pride's web site at www.pridemobility.com. As a registered member, each time you visit our site, you will have access to the most interactive and honest educational venue available today for people with mobility needs, their families, and friends.

From our home page, click on the button that reads "Owners Club" to enter a page dedicated to current and potential Pride product owners. You will gain access to interviews, stories, recreation ideas, daily living tips, product and funding information, and interactive message boards. On these message boards you are invited to speak with other Pride customers as well as Pride representatives who are available to assist you with any questions or concerns you may have.

My Authorized Pride Provider Is:

Name: _____

Address: _____

Phone Number: _____

Quick Reference Information:

Scooter Model: _____

Serial Number: _____

Purchase Date: _____

NOTE: If you ever lose or misplace your warranty card or your copy of this manual, call or write to us and we will be glad to send you a new one immediately.

II. SAFETY

GENERAL



WARNING! Do not operate your new Scooter for the first time without completely reading and understanding this owner's manual.

Your Scooter is a state-of-the-art life-enhancement device designed to increase mobility. Pride provides an extensive variety of products to best fit the individual needs of the Scooter user. Please be aware that the final selection and purchasing decision regarding the type of Scooter to be used is the responsibility of the Scooter user who is capable of making such a decision and his/her healthcare professional (i.e., medical doctor, physical therapist, etc.).

The contents of this manual are based on the expectation that a mobility device expert has properly fitted the Scooter to the user and has assisted the prescribing healthcare professional and/or the authorized Pride provider in the instruction process for the use of the product.

There are certain situations, including some medical conditions, where the Scooter user will need to practice operating the Scooter in the presence of a trained attendant. A trained attendant can be defined as a family member or care professional specially trained in assisting a Scooter user in various daily living activities.

As you begin using your Scooter during daily activities, you will probably encounter situations in which you will need some practice. Simply take your time and you will soon be in full and confident control as you maneuver through doorways, on and off elevators, up and down ramps, and over moderate terrain.

Below are some precautions, tips, and other safety considerations that will help the user become accustomed to operating the Scooter safely.

MODIFICATIONS

Pride has designed and engineered your Scooter to provide maximum mobility and utility. A wide range of accessories is available from your Pride provider to further customize your Scooter to better suit your needs and/or preferences. However, under no circumstances should you modify, add, remove, or disable any feature, part, or function of your Scooter.



WARNING! Do not modify your Scooter in any way not authorized by Pride. Unauthorized modifications may result in personal injury and/or damage to your Scooter.

II. SAFETY

PRE-RIDE SAFETY CHECK

Get to know the feel of your Scooter and its capabilities. Pride recommends that you perform a safety check before each use to make sure your Scooter operates smoothly and safely. For details on how to perform these necessary inspections, see XII. "Care and Maintenance."

Perform the following inspections prior to using your Scooter:

- Check for proper tire inflation. Maintain **30-35 psi** in each tire (if equipped with pneumatic tires).
- Check all electrical connections. Make sure they are tight and not corroded.
- Check all controller connections to the utility tray. Make sure they are secured properly.
- Check the brakes.
- Check battery charge.



WARNING! It is critically important that 30-35 psi tire pressure be maintained in pneumatic tires at all times. Failure to maintain 30-35 psi tire pressure in pneumatic tires at all times may result in catastrophic tire and/or wheel failure, causing serious personal injury and/or damage to your Scooter.

WARNING! Do not carry passengers on your Scooter. Carrying passengers on your Scooter may result in personal injury and/or property damage.

If you discover a problem, contact your authorized Pride provider for assistance.

WEIGHT LIMITATIONS

Your Scooter is rated for a 300-lb. maximum weight limit.



WARNING! Exceeding the weight limit voids your warranty and may result in personal injury and damage to your Scooter. Pride will not be held responsible for injuries and/or property damage resulting from failure to observe weight limitations.

INCLINE INFORMATION

More and more buildings have ramps with specified degrees of inclination, designed for easy and safe access. Some ramps may have turning switchbacks (180-degree turns) that require you to have good cornering skills on your Scooter.

- Proceed with extreme caution as you approach the downgrade of a ramp or other incline.
- Take wide swings with your Scooter's front wheel(s) around any tight corners. If you do that, the Scooter's rear wheels will follow a wide arc, not cut the corner short, and not bump into or get hung up on any railing corners.
- When driving down a ramp, keep the Scooter's speed adjustment set to the slowest speed setting to ensure a safely controlled descent. See V. "Your Legend."
- Avoid sudden stops and starts.

II. SAFETY

When climbing an incline, try to keep your Scooter moving. If you must stop, start up again slowly, and then accelerate cautiously. When driving down an incline, do so by setting the speed adjustment dial to the slowest setting and driving in the forward direction only. If your Scooter starts to move down the incline faster than you anticipated or desired, allow it to come to a complete stop by releasing the throttle control lever. Then push the throttle control lever forward slightly to ensure a safely controlled descent.

WARNING! When climbing an incline, do not zigzag or drive at an angle up the face of the incline. Drive your Scooter straight up the incline. This greatly reduces the possibility of a tip or a fall. Always exercise extreme caution when negotiating an incline.



WARNING! You should not travel up or down a potentially hazardous incline (i.e., areas covered with snow, ice, cut grass, or wet leaves).

WARNING! When on any sort of an incline or decline, never place the Scooter in manual freewheel mode while seated on it or standing next to it.

In compliance with the Americans with Disabilities Act of 1990, all handicap public access ramps in the United States are required to have a maximum slope of five degrees. Therefore, Pride recommends that the maximum degree of an incline you attempt to safely ascend or descend on your Scooter does not exceed those shown in figures 1 and 2.

These tests were conducted with the Legend's seat in the highest position and adjusted backward on the seat base to its farthest rearward position. Use this information as a guideline. Your Legend's ability to travel up inclines is affected by your weight, your Scooter's speed, your angle of approach to the incline, and your Scooter setup.

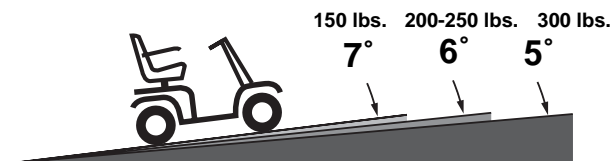

FIGURE 1. MAXIMUM RECOMMENDED INCLINE ANGLE FOR THE 3-WHEEL LEGEND

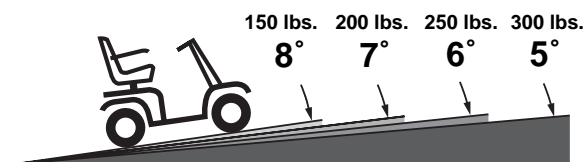

FIGURE 2. MAXIMUM RECOMMENDED INCLINE ANGLE FOR THE 4-WHEEL LEGEND



WARNING! Any attempt to climb or descend a slope steeper than shown in figures 1 and 2 may put your Scooter in an unstable position and cause it to tip, resulting in personal injury.

II. SAFETY

When you approach an incline, it is best to lean forward. See figures 3 and 4. This shifts the center of gravity of you and your Legend toward the front of the Scooter for improved stability.



WARNING! Do not exceed the incline guidelines or any other specifications presented in this manual.



FIGURE 3. NORMAL DRIVING POSITION

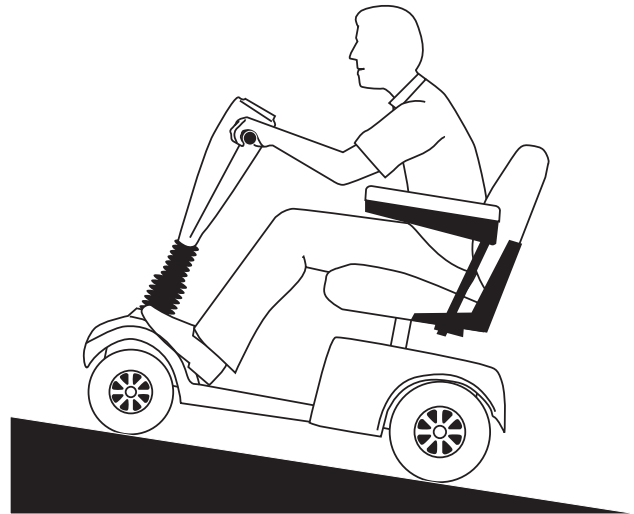

FIGURE 4. INCREASED STABILITY DRIVING POSITION

CORNERING INFORMATION

Excessively high cornering speeds can create the possibility of tipping. Factors which affect the possibility of tipping include, but are not limited to, cornering speed, steering angle (how sharply you are turning), uneven road surfaces, inclined road surfaces, riding from an area of low traction to an area of high traction (such as passing from a grassy area to a paved area – especially at high speed while turning), and abrupt directional changes. High cornering speeds are not recommended. If you feel that you may tip over in a corner, reduce your speed and steering angle (i.e., lessen the sharpness of the turn) to prevent your Scooter from tipping.



WARNING! When cornering sharply, reduce your speed. When using your Scooter at higher speeds, do not corner sharply. This greatly reduces the possibility of a tip or fall. To avoid personal injury or property damage, always exercise common sense when cornering.

II. SAFETY

BRAKING INFORMATION

Your Scooter is equipped with two powerful brake systems:

1. Regenerative: Uses electricity to rapidly slow the vehicle when the throttle control lever returns to the center/stop position; and
2. Disc Park Brake: Activates mechanically after regenerative braking slows the vehicle to near stop, or when power is removed from the system for any reason.

OUTDOOR DRIVING SURFACES

Your Scooter is designed to provide optimum stability under normal driving conditions—dry, level surfaces composed of concrete, blacktop, or asphalt. However, Pride recognizes that there will be times when you will encounter other surface types. For this reason, your Scooter is designed to perform admirably on packed soil, grass, and gravel. Feel free to use your Scooter safely on lawns and in park areas.

- Reduce your Scooter's speed when driving on uneven terrain and/or soft surfaces.
- Avoid tall grass that can become tangled in the running gear.
- Avoid loosely packed gravel and sand.
- If you feel unsure about a driving surface, avoid that surface.

STATIONARY OBSTACLES (STEPS, CURBS, ETC.)

Proceed with extreme caution when driving near raised surfaces, unprotected ledges and/or drop-offs (curbs, porches, stairs, etc.).



WARNING! Do not attempt to have your Scooter climb or descend an obstacle that is inordinately high. Serious personal injury and/or damage may result.

WARNING! Do not attempt to have your Scooter proceed backwards down any step, curb, or other obstacle. This may cause the Scooter to tip and cause personal injury.

II. SAFETY

PUBLIC ROADS AND PARKING LOTS



WARNING! You should not operate your Scooter on public streets and roadways. Be aware that it may be difficult for traffic to see you when you are seated on your Scooter. Obey all local pedestrian traffic rules. Wait until your path is clear of traffic, and then proceed with extreme caution.

NOTE: Safety accessories like reflectors, fluorescent flags, and various lighting packages are available to order from your authorized Pride provider.

INCLEMENT WEATHER PRECAUTIONS



WARNING! Pride recommends that you do not operate your Scooter in icy or slippery conditions or on salted surfaces (i.e., walks or roads). Such use may result in an accident, personal injury, or adversely affect the performance and safety of your Scooter.

WARNING! Pride recommends that you do not expose your Scooter to any type of moisture at any time (rain, snow, mist, or wash). Such exposure can damage your Scooter. Never operate your Scooter if it has been exposed to moisture until it has dried thoroughly.

MANUAL FREEWHEEL MODE

Your Scooter is equipped with a manual freewheel lever that when pulled up allows the Scooter to be pushed. For more information about how to place your Scooter into and out of manual freewheel mode, see V. “Your Legend.”



WARNING! Do not use your Scooter in manual freewheel mode without an attendant present. Personal injury may result.

WARNING! Do not attempt to personally place your Scooter in manual freewheel mode while seated on it. Personal injury may result. Ask an attendant for assistance if necessary.

WARNING! Do not place your Scooter in manual freewheel mode while on an incline. The Scooter could roll uncontrollably on its own, causing personal injury.

TIRE INFLATION

If your Scooter is equipped with pneumatic tires, you should check or have the air pressure checked at least once a week. Proper inflation pressures will prolong the life of your tires and help ensure the smooth operation of your Scooter.



WARNING! It is critically important that pneumatic tires be inflated to 30-35 psi. Do not underinflate or overinflate your tires. Improper tire pressure may result in catastrophic tire and/or wheel failure. Serious personal injury and/or property damage may result.

WARNING! Inflate your Scooter drive tires from a regulated air source with an available pressure gauge. Minimum air pressure for Scooter drive tires is 30-35 psi. Inflating your tires from an unregulated air source could overinflate them, resulting in a burst tire and/or personal injury.

II. SAFETY

STAIRS AND ESCALATORS

Scooters are not designed to travel up or down stairs or escalators. Always use an elevator.



WARNING! Do not use your Scooter to negotiate steps or escalators. You may cause injury to yourself and to others and damage your Scooter.

DOORS

- Determine if the door opens toward or away from you.
- Use your hand to turn the knob or push the handle or push-bar.
- Drive your Scooter gently and slowly forward to push the door open. Or drive your Scooter gently and slowly backwards to pull the door open.

ELEVATORS

Modern elevators have a door edge safety mechanism that, when pushed, reopens the elevator door(s).

- If you are in the doorway of an elevator when the door(s) begin to close, push on the rubber door edge or allow the rubber door edge to contact the Scooter and the door will reopen.
- Use care that pocketbooks, packages, or Scooter accessories do not become caught in elevator doors.

LIFT/ELEVATION PRODUCTS

If you will be traveling with your Scooter, you may find it necessary to use a lift/elevation product to aid in transportation. Pride recommends that you closely review the instructions, specifications, and safety information set forth by the manufacturer of the lift/elevation product before using that product.

BATTERIES

In addition to following the warnings below, be sure to comply with all other battery handling information. For more information about your Scooter's batteries, see VI. "Batteries and Charging."



WARNING! (32 AH) Scooter batteries weigh 25 lbs. each. If you are unable to lift that much weight, be sure to get help. Lifting beyond your capacity can result in personal injury.

WARNING! Battery posts, terminals, and related accessories contain lead and lead compounds. Wash hands after handling.

WARNING! Always protect the batteries from freezing and never charge a frozen battery. Charging a frozen battery may result in personal injury and/or damage to the battery.

PREVENTING UNINTENDED MOVEMENT



WARNING! If you anticipate being seated in a stationary position for an extended period of time, turn off the power. This will prevent unexpected motion from inadvertent throttle control lever contact. Failure to do so may result in personal injury.

II. SAFETY

MOTOR VEHICLE TRANSPORT

Currently, there are no standards approved for tie-down systems in a moving vehicle of any type to transport a person while seated in a Scooter.

Although your Scooter may be equipped with a positioning belt, this belt is not designed to provide proper restraint during motor vehicle transport. Anyone traveling in a motor vehicle should be properly secured in the motor vehicle seat with safety belts fastened securely.



WARNING! Do not sit on your Scooter while it is in a moving vehicle. Personal injury and/or property damage may result.

WARNING! Always be sure your Scooter and its batteries are properly secured when it is being transported. Failure to do so may result in personal injury and/or damage to your Scooter.

GETTING ONTO AND OFF OF YOUR SCOOTER

Getting onto and off of your Scooter requires a good sense of balance. Please observe the following safety tips when getting onto and off of your Scooter:

- Power down your Scooter. See VII. “Operation.”
- Ensure that your Scooter is not in manual freewheel mode. See V. “Your Legend.”
- Make certain that the seat is locked into place and the key is removed from the key switch.
- The seat armrests can be flipped up to make getting on and off the Scooter easier.



WARNING! Position yourself as far back as possible in the Scooter seat to prevent the Scooter from tipping and causing injury.

WARNING! Avoid using your armrests for weight bearing purposes. Such use may cause the Scooter to tip and cause personal injury.

WARNING! Avoid putting all of your weight on the floorboard. Such use may cause the Scooter to tip and cause personal injury.

POSITIONING BELTS

Your authorized Pride provider, therapist(s), and other healthcare professionals are responsible for determining your requirement for a positioning belt in order to operate your Scooter safely.



WARNING! If you require a positioning belt to safely operate your Scooter, make sure it is fastened securely. Serious personal injury may result if you fall from the Scooter.

II. SAFETY

REACHING AND BENDING

Avoid reaching or bending while driving your Scooter. When reaching, bending, or leaning while seated on your Scooter, it is important to maintain a stable center of gravity and keep the Scooter from tipping. Pride recommends that the Scooter user determine his/her personal limitations and practice bending and reaching in the presence of a qualified healthcare professional.



WARNING! Do not bend, lean, or reach for objects if you have to pick them up from the floor by reaching down between your knees. Movements such as these may change your center of gravity and the weight distribution of the Scooter and cause your Scooter to tip, possibly resulting in personal injury. Keep your hands away from the tires when driving.

PRESCRIPTION DRUGS/PHYSICAL LIMITATIONS

The Scooter user must exercise care and common sense when operating his/her Scooter. This includes awareness of safety issues when taking prescribed or over-the-counter drugs or when the user has specific physical limitations.



WARNING! Consult your physician if you are taking prescribed or over-the-counter medication or if you have certain physical limitations. Some medications and limitations may impair your ability to operate your Scooter in a safe manner.

ALCOHOL

The Scooter user must exercise care and common sense when operating his/her Scooter. This includes awareness of safety issues while under the influence of alcohol.



WARNING! Do not operate your Scooter while you are under the influence of alcohol, as this may impair your ability to drive safely.

REMOVABLE PARTS



WARNING! Do not attempt to lift or move a Scooter by any of its removable parts. Personal injury and damage to the Scooter may result.

III. EMI / RFI

EMI/RFI WARNINGS

Laboratory tests performed by the Food and Drug Administration (FDA) have shown that radio waves can cause unintended motion of electric mobility vehicles. Radio waves are a form of electromagnetic energy (EM). When electromagnetic energy adversely affects the operation of an electrical device, that adverse effect is called *Electromagnetic Interference (EMI) or Radio Frequency Interference (RFI)*.

EMI/RFI FREQUENTLY ASKED QUESTIONS (FAQS)

The following FAQs summarize what you should know about EMI/RFI. Use this information to minimize the risk that EMI/RFI will adversely affect your Scooter.

Where do radio waves come from?

Radio waves are emitted from the antennas of cellular phones, mobile two-way radios (such as walkie-talkies and CBs), radio stations, TV stations, amateur radio (HAM) transmitters, wireless computer links, microwave sources, and paging transmitters. Radio waves are a form of electromagnetic energy (EM). EM is more intense closer to transmitting antennas, which are sources of emission. The greater the transmission strength, the greater the concern to electric mobility vehicle users.

If EMI/RFI affects my Scooter, what kind of motion should I expect?

This is difficult to predict. The answer would depend on a number of factors:

- The strength of the radio waves.
- The construction of your particular Scooter.
- The location of your Scooter (whether it is on the level ground or on an incline).
- Whether or not your Scooter is in motion.

The motion of any electric Scooter affected by EMI/RFI can be erratic. The Scooter may come to a sudden stop or move in an uncontrolled manner. Also, it is possible for EMI/RFI to release the brakes of an electric Scooter. Some intense EMI/RFI can even damage the control system components of an electric Scooter.

Is there any way to know for certain whether or not radio waves are the cause of any unintended Scooter motion?

Unfortunately, EMI/RFI may be difficult to recognize, because the signals from radio sources are invisible and may be intermittent. However, the FDA recommends that you report all incidents of unintended motion or unintended brake release of your electric Scooter to its manufacturer and, if possible, determine whether or not there was a radio wave source nearby at the time of the incident.

One precaution you can take against unintended motion of your Scooter is to make certain that you or someone else is not the cause of the unintended motion.

- Turn off your Scooter by removing the key from the key switch when you are mounting or dismounting your Scooter.
- Never leave the key in the key switch of an unattended Scooter.
- By following these steps, you greatly reduce the risk of you or anyone else inadvertently bumping the throttle control levers and causing the Scooter to move unintentionally.

Has anyone been injured by the erratic, unintended motion of an electric Scooter?

The FDA has reports of injuries that resulted from uncontrolled motion of electric Scooters, but it is not clear just how many of those injuries were actually caused by EMI/RFI.

III. EMI / RFI

Are all electric Scooters susceptible to EMI/RFI?

Each make and model of electric Scooter differs in its ability to resist EMI/RFI. Every Scooter has a particular level of resistance to EMI/RFI. This resistance is measured in volts per meter (V/m). A higher resistance level offers greater protection against EMI/RFI. In other words, an electric Scooter with a high resistance level is less likely to be affected by a strong radio source than is an electric Scooter with a low resistance level.

What is the FDA doing about the problem?

The FDA has written to electric Scooter manufacturers and requested that those manufacturers test their new Scooter models to be certain that they provide a reasonable degree of resistance against EMI/RFI. The FDA has stated that all newly manufactured electric Scooter models should have a resistance level of at least 20 V/m. This level of resistance provides a reasonable degree of protection against the common sources of EMI/RFI.

The FDA has also requested or recommended that:

- Electric Scooter manufacturers clearly label new products with their resistance level or state that the resistance level is not known.
- The labeling or informational material supplied with new electric Scooters must explain what the resistance level means and warn users about the possibility of EMI/RFI and how to avoid it.
- Electric Scooter manufacturers undertake an educational program to inform electric Scooter users and their caregivers about the problems associated with EMI/RFI and about the actions they can take to minimize the risk of EMI/RFI.
- While there is no exact way to tell if your Scooter is totally safe, an immunity level of 20 V/m (May 1994) is generally achievable and useful. This product has been tested and passed at an immunity level of 20 V/m.

What can I do to find out if my Scooter is likely to be affected by EMI/RFI?

If you have had your Scooter for some time and have not experienced any unintended motion, it is not likely that you will have a problem in the future. However, it is always possible that EMI/RFI problems could arise if you are close to a source of radio waves. Therefore, it is very important for you to be alert to this possibility. The Scooter meets or exceeds a resistance level of at least 20 V/m.

What can I do to reduce the risk of my Scooter being affected by EMI/RFI?

Here are some precautions you can take:

- Do not turn on or use hand-held personal communications devices, such as citizens band (CB) radios and cellular phones, while your Scooter is turned on.
- Be aware of nearby radio wave transmitters, such as radio or TV stations and hand-held or mobile two-way radios. Try not to operate your Scooter too close to those transmitters. For example, if you are on an electric Scooter with a resistance level of at least 20 V/m, you should remain at least three feet from a hand-held two-way radio and at least ten feet from a mobile two-way radio.
- Be aware that adding accessories and/or components, or modifying your Scooter in any way, may change its EMI/RFI resistance level and may make it more susceptible to interference from radio wave sources.

What should I do if my Scooter moves unexpectedly?

If unintended motion or unintended brake release occurs, turn off your Scooter (by removing the key) as soon as it is safe to do so.

If my Scooter moves unintentionally, where should I report the incident?

Call your authorized Pride provider.

IV. SPECIFICATIONS

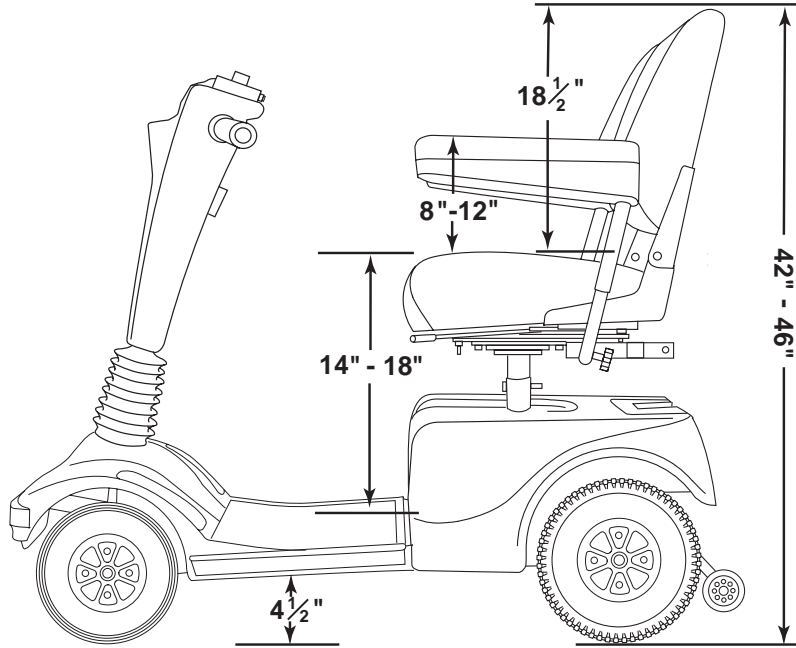
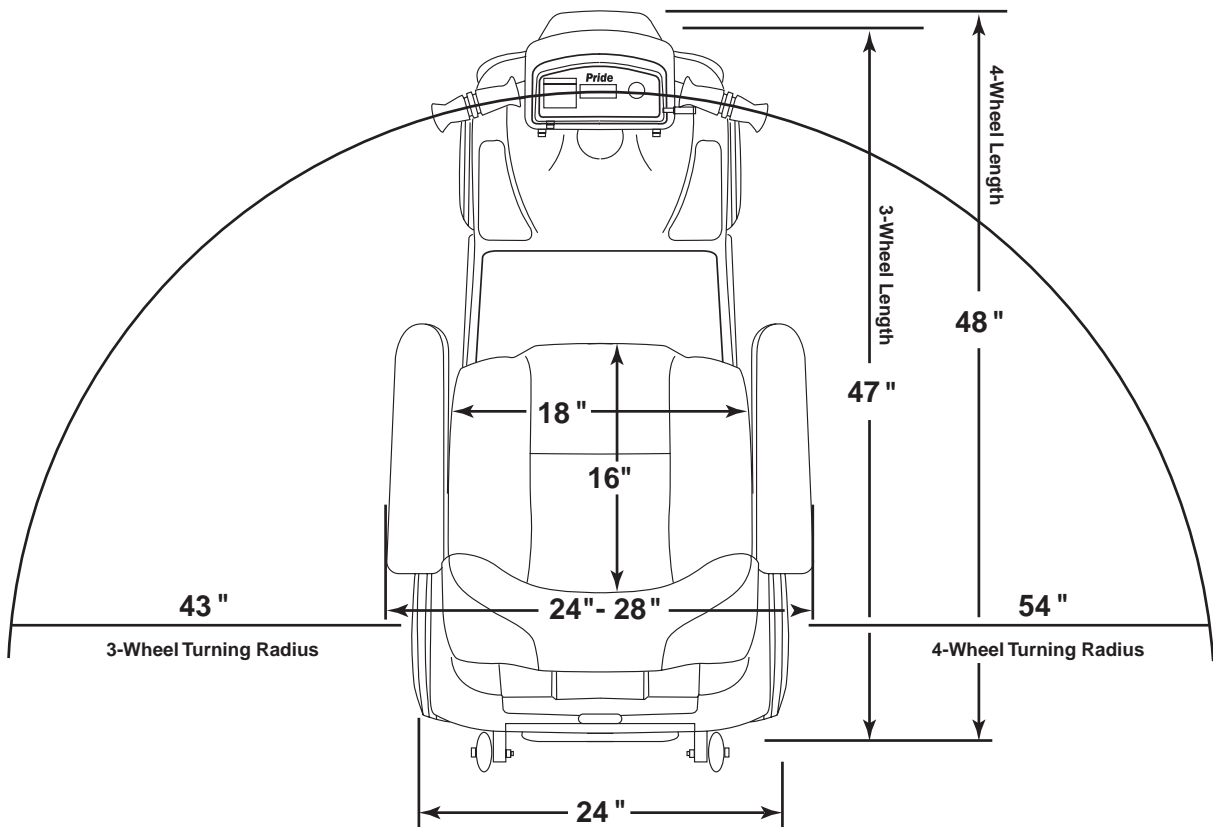

FIGURE 5. LEGEND DIMENSIONS



IV. SPECIFICATIONS

Model Numbers	Legend 3-Wheel: SC300; Legend 4-Wheel: SC340
Body Color	Painted - Champagne
Length	Legend 3-Wheel: 47 in. Legend 4-Wheel: 48 in.
Width	24 in.
Tires	Type: Pneumatic Front: 4 in. x 9 in. Rear: 4 in. x 10 in.
Weight Capacity	300 lbs. (maximum)
Battery Type (Batteries not included)	Two 12 volt, 32 AH, U-1 type, SLA (sealed lead-acid)
Horsepower	1.1 hp (peak)
Charger	Onboard 3-amp charger
Speed (max)	Variable up to 5.25 mph.
Maximum Grade	See figures 1 and 2
Range	Up to 20-25 miles per charge (varies)
Turning Radius	Legend 3-Wheel: 43 in. Legend 4-Wheel: 54 in.
Seating	Style: Medium-back contour Dimensions: 18 in. width x 16 in. depth (usable) x 18.5 in. back height (usable) Seat cover material: Vinyl or Fabric Armrests: Matching User adjustable seat height from Scooter deck: 14 in. - 18 in.
Included Features	Adjustable seat height and positioning; external freewheel release lever; front basket; circuit breaker; easily accessible battery charger; A/C plug
Brakes	Electronic regenerative braking and electromechanical disc brake
Rear Wheel Drive	Transaxle – 24 volts
Wheels	Aluminum alloy wheels
Tiller Type	Adjustable, 3 position self-locking
Freewheel Mechanism	Freewheel release lever located on transaxle
Weight of Scooter	Total weight of 3-Wheel (with two 12 volt, 32 AH batteries = 165 lbs.) Total weight of 4-Wheel (with two 12 volt, 32 AH batteries = 171 lbs.) Component breakdown: Front section: 3-Wheel 35 lbs. 4-Wheel 41 lbs. Rear section (without batteries or rear shroud): 45 lbs. Seat: 35 lbs. Batteries (note: two batteries are required per Scooter) 12 volt, 32 AH: 25 lbs.(each)
Front-to-Rear Lockup	Lock pin and dual camlock lever system
Ground Clearance	4.5 in.
Optional Accessories	Single crutch holder, double crutch holder, oxygen tank holder, walker holder, forearm crutch holder, rear basket, cup holder, dust cover, weather breaker canopy, safety flag

V. YOUR LEGEND

Your Legend is a motorized electric Scooter designed to enhance your personal mobility. The Legend is an indoor/outdoor Scooter designed to travel primarily on smooth surfaces such as sidewalks, roads, parking lots, floors, and driveways. For easy transportation or storage, you can disassemble your Legend into six components. See figure 6.



FIGURE 6. LEGEND COMPONENTS

CONTROL CONSOLE ASSEMBLY

The control console assembly houses all of the controls you need to drive your Legend, including the key, the key switch, the speed adjustment dial, the throttle control levers, the battery condition meter, and the horn button. See figure 7.



FIGURE 7. CONTROL CONSOLE ASSEMBLY

V. YOUR LEGEND

Do not expose the control console assembly to moisture. In the event the console does become exposed to moisture, do not attempt to operate your Legend until it has thoroughly dried.

Key Switch

- Fully insert the key into the key switch to power up (turn on) your Legend.
- Pull the key out to power down (turn off) your Legend.



WARNING! If the key is removed from the key switch while your Legend is in motion, the electronic brakes engage and your Legend comes to an abrupt stop!

Speed Adjustment Dial

This control dial allows you to preselect and limit your Legend's top speed.

- The image of the tortoise represents the slowest speed setting.
- The image of the hare represents the fastest speed setting.

Throttle Control Lever

This lever allows you to control the forward and reverse speed of your Legend up to the maximum speed you preset with the speed adjustment dial.

- Place your right hand on the right handgrip and your left hand on the left handgrip.
- Use your right thumb to push the right side of the lever to disengage your Legend's brakes and move forward.
- Release the lever and allow your Legend to come to a complete stop before pushing the other side of the lever to move in reverse.
- When the throttle is completely released, it automatically returns to the center "stop" position and engages your Legend's brakes.

Batter Condition Meter

Whenever you have the key fully inserted, this meter gives an approximate reading of your Legend's battery voltage.

Horn Button

- The key must be fully inserted into the key switch for the horn to be operational.
- This button activates a warning horn.
- Do not hesitate to use the warning horn when its use could prevent accident or injury.

V. YOUR LEGEND

REAR SECTION

The onboard battery charger, the charger power cord, the batteries, the electronic controller assembly, the main circuit breaker, the manual freewheel lever, and the motor/transaxle assembly are located beneath the shroud on the rear section of your Legend. See figure 8. Refer to IX. “Disassembly and Assembly” for instructions on removing the rear shroud.

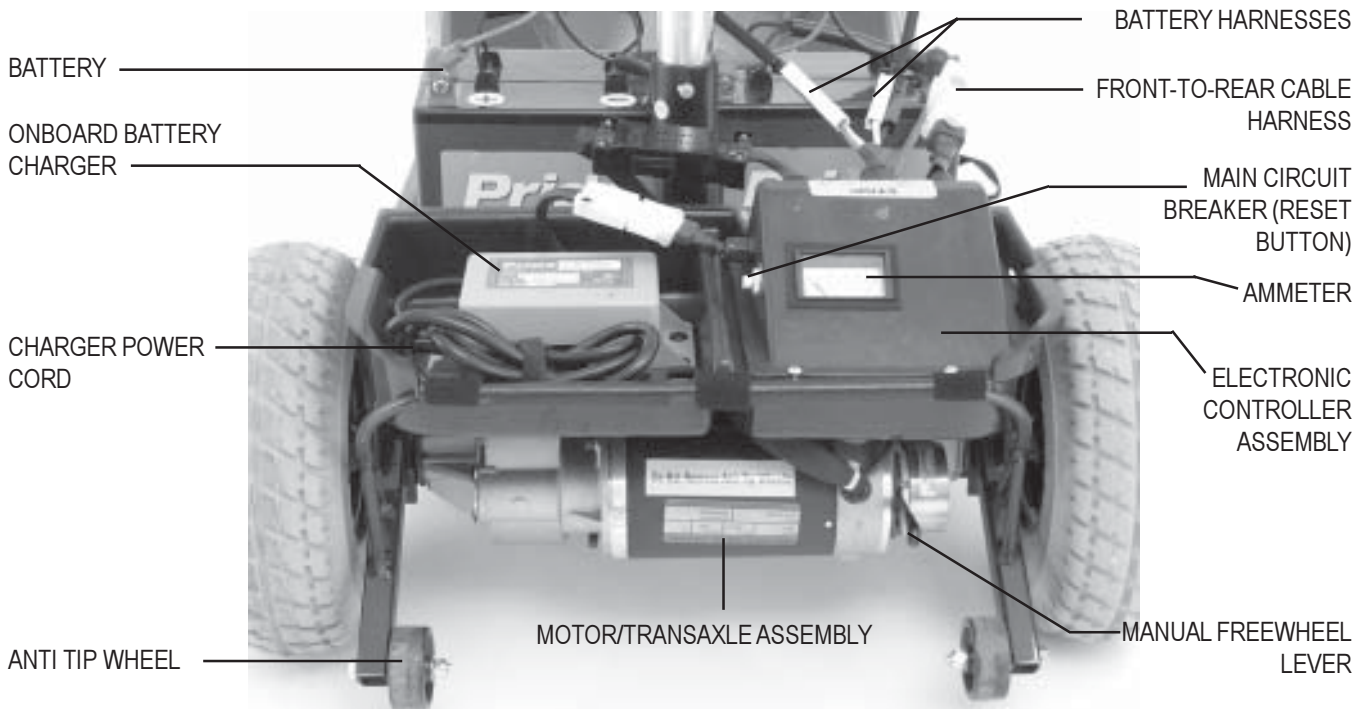

FIGURE 8. UTILITY TRAY COMPONENTS

Onboard Battery Charger

The onboard battery charger converts household current (AC) to direct current (DC) and charges the batteries of your Legend. See VI. “Batteries and Charging.”

- The charger is located on the utility tray. See figure 8.
- The charger is a gray-colored plastic box with a green LED indicator on the exterior of the case.

Batteries

The batteries store the electrical energy that powers your Legend. See VI. “Batteries and Charging.”

Electronic Controller Assembly

This assembly receives electrical signals from the console controls and sends power to the motor, the brakes, and the lighting system.

Main Circuit Breaker

When the voltage in your Legend’s batteries becomes low or your Legend is heavily strained because of excessive loads or steep inclines, the main circuit breaker may trip to protect your Legend’s motor and electronics from damage.

V. YOUR LEGEND

Do not expose the electronic controller assembly to moisture. In the event that the electronic controller assembly does become exposed to moisture, do not attempt to operate your Legend until the assembly has thoroughly dried.

- The main circuit breaker (reset button) is mounted on the left side of the electronic controller assembly cover. See figure 8.
- The main circuit breaker reset button pops out when the breaker trips.
- When the breaker trips, the entire electrical system of your Legend is shut down.
- Allow a minute or so for your Legend's electronics to "rest."
- Push in the reset button to reset the breaker.
- If the breaker trips frequently, you may need to charge your batteries more often. You may also need to have your Pride provider perform a load test on your Legend's batteries.
- If the main circuit breaker trips repeatedly, see your authorized Pride provider for service.

Manual Freewheel Lever



WARNING! Before placing your Legend in or taking it out of manual freewheel mode, make certain that the key is removed from the key switch. Even though the motor of your Legend is disengaged from the drive system when your Scooter is put in manual freewheel mode, the motor can still run if the throttle lever is pushed. Never sit on a Scooter when it is in manual freewheel mode. Never put a Scooter in manual freewheel mode on any incline.

Whenever you need, or want, to push your Legend for short distances, you can put it in manual freewheel mode.

- The manual freewheel lever is located on the end of the motor/transaxle assembly at the right rear of the Legend. See figure 8.
- Pull up on the manual freewheel lever to disable the drive system and brake systems.
- You will then be able to push your Legend.
- Push down on the manual freewheel lever to reengage the drive system and the brake system and take your Legend out of manual freewheel mode.

Motor/Transaxle Assembly

The motor/transaxle assembly is the electromechanical unit that converts the electrical energy of your Legend's batteries into the controlled mechanical energy that drives the Legend's wheels. See figure 8.

Anti-Tip Wheels

The anti-tip wheels are an integral and important safety feature of your Legend. Do not, under any circumstances, remove the anti-tip wheels from your Legend. See figure 8.

VI. BATTERIES AND CHARGING

Your Legend requires two long-lasting, 12-volt, deep-cycle batteries that are sealed and maintenance free. They are recharged by an onboard 3-amp charging system.

- Charge your Legend's batteries prior to using it for the first time.
- Keep the batteries fully charged to keep your Scooter running smoothly.

READING YOUR BATTERY VOLTAGE

The battery condition meter on the control console assembly indicates the approximate strength of your batteries using a color code. Green indicates fully charged batteries, yellow a draining charge, and red indicates that an immediate recharge is necessary. See figure 9.

You can also check the charge by the ammeter, located on the electronic controller assembly. The charger power cord must be plugged into a standard wall outlet in order to obtain a reading. When the amperage reading is at or near zero amps, charging is complete. See figure 10.

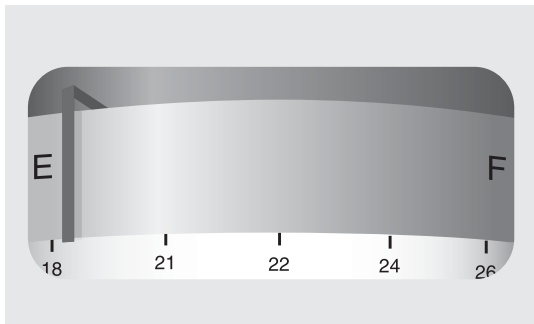

FIGURE 9. BATTERY CONDITION METER



FIGURE 10. AMMETER INDICATES BATTERY IS FULLY CHARGED

CHARGING YOUR BATTERIES

Follow these easy steps to charge your batteries safely:

1. Position your Scooter close to a standard wall outlet.
2. Remove the key from the key switch.
3. Make certain that the freewheel lever is in the drive (down) position.
4. Plug the charger power cord into the charger power cord receptacle on your Scooter.
5. Extend the charger power cord and plug it into the wall outlet. It is recommended that you charge your batteries for 8 to 14 hours.
6. When the batteries are fully charged, unplug the charger power cord from the wall outlet and then from the charger power cord receptacle.

NOTE: There is a charger inhibit function on your Scooter. The Scooter will not run and the battery condition meter will not operate while the batteries are charging.

VI. BATTERIES AND CHARGING

BATTERIES AND CHARGING-FREQUENTLY ASKED QUESTIONS (FAQS)

How does the charger work?

When your Legend's battery voltage is low, the charger works harder, sending more electrical current to the batteries to bring up their charge. As the batteries approach a full charge, the charger sends less and less electrical current. When the batteries are fully charged, the current sent from the charger is at nearly zero amperage. Therefore, when the charger is plugged in, it maintains the charge on your Legend's batteries, but does not overcharge them. We do not recommend that you charge your Legend's batteries for more than 24 consecutive hours.

What if my Legend's batteries won't charge?

- Ensure that the red (+) and black (-) battery cables are connected properly to the battery terminals.
- Ensure that both black and white battery harnesses are plugged into each other.
- Ensure that both ends of the charger power cord are inserted fully.

Can I use a different charger?

For the safest, most efficient, and balanced charging of your Legend's batteries, we prefer and highly recommend simultaneous charging of both batteries with the onboard battery charger.

How often must I charge the batteries?

Two major factors must be considered when deciding how often to charge your Legend's batteries:

- All day Scooter use on a daily basis.
- Infrequent or sporadic Scooter use.

With these considerations in mind, you can determine how often and for how long you should charge your Legend's batteries. We designed the onboard charger so that it will not overcharge your Scooter's batteries. However, you may encounter some problems if you do not charge your batteries often enough and if you do not charge them on a regular basis. Following the five guidelines below will provide safe and reliable battery operation and charging.

- If you use your Legend daily, charge its batteries as soon as you finish using it for the day. Your Legend will be ready each morning to give you a full day of service. We recommend that you charge your Legend's batteries for 8 to 14 hours after daily use.
- If you use your Legend once a week or less, charge its batteries at least once a week for 12 to 14 hours at a time.
- Keep your Legend's batteries fully charged.
- Avoid deeply discharging your Legend's batteries.
- Do not charge your Legend's batteries for more than 24 consecutive hours.

VI. BATTERIES AND CHARGING

How can I get maximum range or distance per charge?

Rarely will you have ideal driving conditions—smooth, flat, hard driving surfaces with no wind or curves. Often, you will face hills, sidewalk cracks, uneven and loosely packed surfaces, curves, and wind, all of which affect the distance or running time per battery charge. Below are a few suggestions for obtaining the maximum range per battery charge.

- Always fully charge your Legend's batteries prior to daily use.
- Maintain 30-35 psi (pounds per square inch) in each tire.
- Plan your route ahead to avoid as many hills, cracked, broken, or soft surfaces as possible.
- Limit your baggage weight to essential items.
- Try to maintain an even speed while your Legend is in motion.
- Avoid stop-and-go driving.

What type and size of battery should I use?

We recommend deep-cycle batteries that are sealed and maintenance free. Both sealed lead-acid and gel cell are deep-cycle batteries that are similar in performance. Do not use wet-cell batteries, which have removable caps.



CAUTION! Do not remove the caps from sealed batteries. Water cannot be added to sealed batteries. Cap removal voids the battery warranty and may cause damage to the batteries and to your Legend.

Use these specifications to reorder deep-cycle batteries:

Type: Deep-cycle (sealed lead-acid or gel cell)
Size: U-1
Voltage: 12 volts each
Amperage: 32 AH (amp hours)

To change a battery in your Legend:



WARNING! Battery posts, terminals, and related accessories contain lead and lead compounds. Wash hands after handling.

1. Remove the seat and rear shroud. See IX. "Disassembly and Assembly."
2. Disconnect the battery tie-down strap.
3. Disconnect the black and white battery harness.
4. Disconnect the battery cables from the battery terminals.
5. Remove the old battery.
6. Place a new battery in the battery well.
7. Connect the red battery cable to the positive (+) battery terminal.
8. Connect the black battery cable to the negative (-) battery terminal.
9. Reconnect the black and white battery harness.
10. Reconnect the battery tie-down strap.
11. Reinstall the rear shroud and seat.

VI. BATTERIES AND CHARGING

Why do my new batteries seem weak?

Deep-cycle batteries employ a different chemical technology than that used in car batteries, nickel-cadmium batteries (nicads), and other common battery types. Deep-cycle batteries are specifically designed to provide power, drain down their charge, and then accept a relatively quick recharge.

We work closely with our battery manufacturer to provide batteries that best suit your Legend's specific electrical demands. Fresh batteries arrive daily at Pride and are shipped fully charged to our customers. During shipping, the batteries may encounter temperature extremes that can influence their initial performance. Heat diminishes the charge on the battery; cold slows the available power and extends the time needed to recharge the battery.

It may take a few days for the temperature of your Legend's batteries to stabilize and adjust to their new room or ambient temperature.

More importantly, it takes a few charging cycles (partial draining followed by full recharging) to establish the critical chemical balance that is essential to a deep-cycle battery's peak performance and long life.

Follow these steps to properly break-in your Legend's new batteries for maximum efficiency and service life.

1. Fully recharge any new battery prior to its initial use. This charging cycle brings the battery up to about 88% of its peak performance level.
2. Operate your new Legend in familiar and safe areas. Drive slowly at first, and do not travel too far from your home or familiar surroundings until you have become accustomed to your Legend's controls and have properly broken in your Scooter's batteries.
3. Fully recharge the batteries. They should be at over 90% of their peak performance level.
4. Operate your Legend again.
5. Fully recharge the batteries again.
6. After four or five charging cycles, the batteries are able to receive a charge of 100% of their peak performance level and are able to last for an extended period of time.

How can I ensure maximum battery life?

Fully charged deep-cycle batteries provide reliable performance and extended battery life. Keep your Legend's batteries fully charged whenever possible. Batteries that are regularly and deeply discharged, infrequently charged, or stored without a full charge may be permanently damaged, causing unreliable performance and limited service life.

VI. BATTERIES AND CHARGING

How should I store my Legend and its batteries?

If you plan on not using your Legend for an extended period of time, it is best to:

- Fully charge its batteries prior to storage.
- Disconnect both black and white battery harnesses.
- Store your Legend in a warm, dry environment.
- Avoid storing your Legend where it will be exposed to temperature extremes.



WARNING! If your Legend's batteries do become frozen, do not attempt to charge them. Cold or frozen batteries should be allowed to warm up for several days prior to recharging.

For prolonged storage, you may wish to place several boards under the frame of your Legend to raise the Scooter off of the ground. This takes the weight off the tires and reduces the possibility of flat spots developing on the areas of the tires contacting the ground.

What about public transportation?

If you intend to use public transportation with your Scooter, you must contact the transportation provider in advance to determine their specific requirements.

VII. OPERATION

BEFORE GETTING ON YOUR LEGEND

- Have you fully charged the batteries? See VI. “Batteries and Charging.”
- Is the manual freewheel lever in the drive (down) position? Never leave the manual freewheel lever pulled up unless you are manually pushing your Legend.

GETTING ON YOUR LEGEND

1. Make certain that the key is removed from the key switch.
2. Stand at the side of your Legend.
3. Push down on the seat lock lever and rotate the seat until it is facing you.
4. Make certain that the seat is locked securely in position.
5. Position yourself comfortably and securely in the seat.
6. Push down on the seat lock lever and rotate the seat until you are facing forward.
7. Make certain that the seat is locked securely in position.
8. Make certain that your feet are safely on the floorboard.

PRE-RIDE ADJUSTMENTS AND CHECKS

- Are you positioned comfortably in the seat? See “Getting On Your Legend,” above.
- Is the seat at the proper height? See VIII. “Comfort Adjustments.”
- Is the seat locked securely in place? See VIII. “Comfort Adjustments.”
- Is the tiller at a comfortable setting and locked securely in place? See VIII. “Comfort Adjustments.”
- Is the key fully inserted into the key switch? See V “Your Legend.”
- Is the speed adjustment dial set to a slow setting? See V. “Your Legend.”
- Are you grasping the handgrips with a thumb resting on each side of the throttle control lever?
- Does your Legend’s horn work properly?
- Is your proposed path clear of people, pets, and obstacles?
- Have you planned your route to avoid adverse terrain and as many inclines as possible?

OPERATING YOUR LEGEND

After planning your route:

- Adjust the speed adjustment dial on the control console assembly to your desired speed.
- Press your thumb against the appropriate throttle control lever.
- The electric brake automatically disengages and the Legend accelerates smoothly to the speed you preselected with the speed adjustment dial.

WHETHER YOU ARE DRIVING FORWARD OR IN REVERSE

- Pull on the left handgrip to steer your Legend to the left.
- Pull on the right handgrip to steer your Legend to the right.
- Move the tiller to the center position to drive straight ahead.
- Release the throttle control lever to decelerate and come to a complete stop.
- The electric brake automatically engages when your Legend comes to a stop.

NOTE: The rear-wheel drive transaxle gives your Legend maximum traction with minimal steering effort on your part.

VII. OPERATION

GETTING OFF OF YOUR LEGEND

1. Bring your Legend to a complete stop.
2. Remove the key from the key switch.
3. Push down the seat lock lever and rotate the seat until you are facing toward the side of your Legend.
4. Make certain that the seat is locked securely in position.
5. Carefully and safely get out of the seat and stand to the side of your Legend.
6. You may leave the seat facing to the side to facilitate boarding your Legend the next time you plan to operate it.

VIII. COMFORT ADJUSTMENTS

TILLER ANGLE ADJUSTMENT



WARNING! Remove the key before adjusting the tiller. Never attempt to adjust the tiller while the Scooter is in motion.

You can adjust the tiller to three positions between the forward stop and the Scooter deck.

1. Pull up on the tiller adjustment lever. See figure 11.
2. Move the tiller to a comfortable position.
3. Release the tiller adjustment lever and push the tiller forward making sure it is locked into place.

NOTE: In order to lower the tiller to the Scooter deck, you must first remove the seat and both batteries. See IX. "Disassembly and Assembly."

SEAT HEIGHT ADJUSTMENT

The seat can be repositioned to one of five different heights.

1. Remove the seat from your Legend. See IX. "Disassembly and Assembly."
2. Use the attached ring to pull and remove the ball detent pin from the lower seat post. See figure 12.
3. Raise or lower the seat pedestal to the desired seat height.
4. Hold the seat pedestal at that height and match up the holes in the seat pedestal and in the lower seat post.
5. Fully insert the ball detent pin.
6. Replace the seat.

FRONT-TO-BACK SEAT ADJUSTMENT

The Legend is equipped with a sliding seat that is operated like an automobile seat. You can reposition the Legend's seat forward or rearward.

1. Pull the front-to-back seat release lever to the left. See figure 13.
2. Move the seat forward or rearward.
3. Release the front-to-back seat lever.

SEAT ROTATION

The seat lock lever locks the seat in one of four positions.

1. Push down on the seat lock lever to unlock the seat. See figure 13.
2. Rotate the seat to the desired position.
3. Release the seat lock lever to lock the seat securely in place.

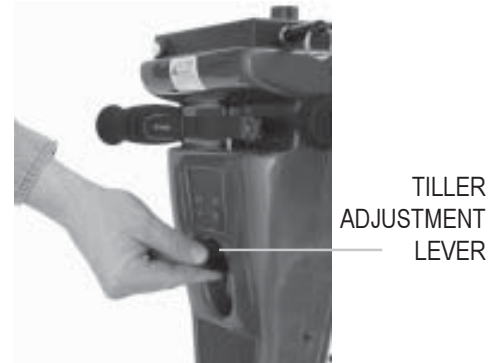

FIGURE 11. TILLER ADJUSTMENT

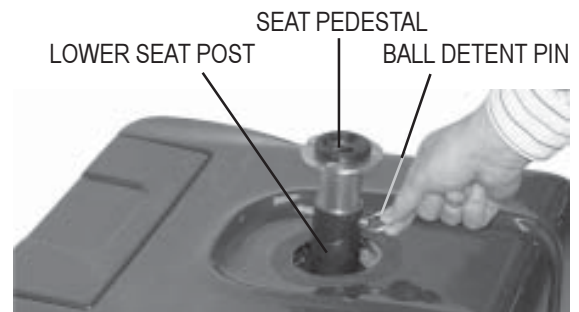

FIGURE 12. SEAT HEIGHT ADJUSTMENT

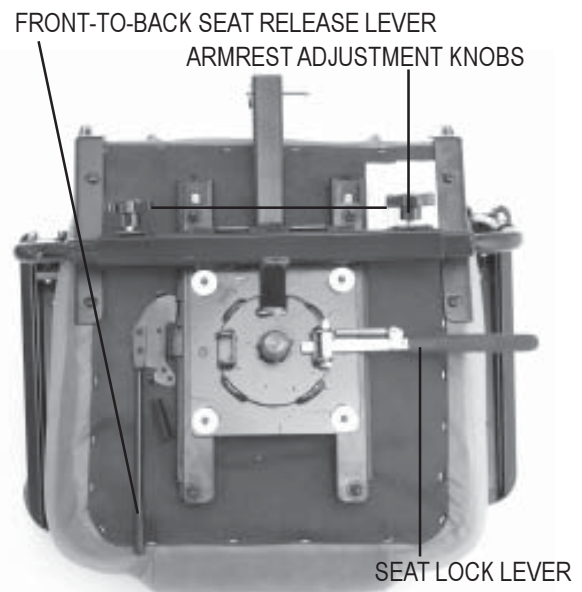

FIGURE 13. SEAT ADJUSTMENTS

VIII. COMFORT ADJUSTMENTS

ARMREST WIDTH ADJUSTMENT

The Legend armrest width can be adjusted inward or outward.

1. Loosen the armrest adjustment knobs at the back of the seat frame. See figures 13 and 14.
2. Slide the armrests in or out to the desired width.
3. Tighten the armrest adjustment knobs as required.

The armrests can also be lifted upward to allow getting on and off of your Legend easier.

ARMREST HEIGHT ADJUSTMENT

Refer to figure 14 when adjusting the armrest height.

You will need the following tools to adjust the height of the armrests:

- 5/32-in. hex key
 - 1/8-in. hex key
 - 7/16-in. wrench
1. Loosen the setscrew on the side of the height adjustment tube with the 1/8-in. hex key.
 2. Loosen and remove the acorn nut and screw holding the height adjustment tube in place.
 3. Raise or lower the height adjustment tube to the desired height.
 4. Align the holes in the adjustment tube with the holes in the armrest upright.
 5. Insert the screw through the holes in both the height adjustment tube and the armrest upright.
 6. Install and tighten the acorn nut.
 7. Tighten the setscrew on the side of the height adjustment tube.
 8. Repeat for the other armrest.

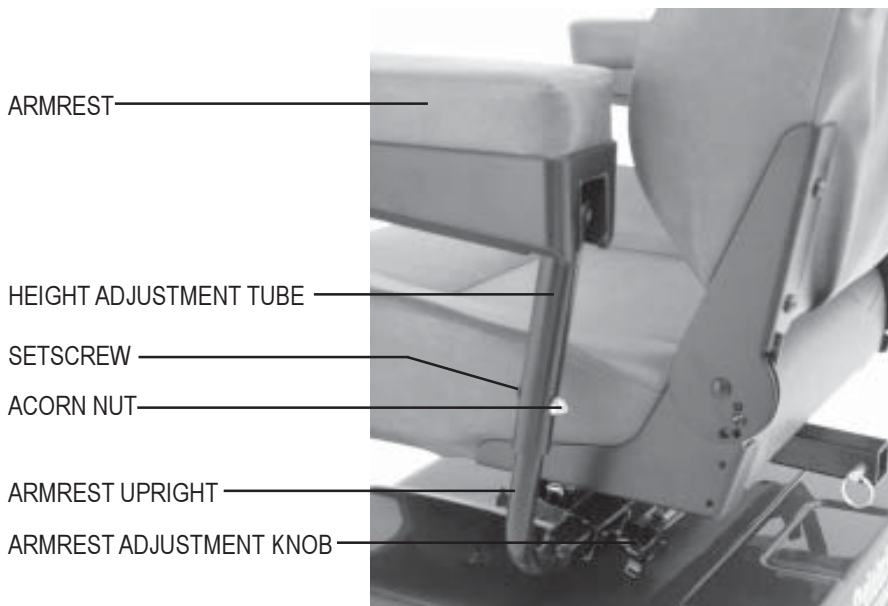

FIGURE 14. ARMREST ADJUSTMENTS

VIII. COMFORT ADJUSTMENTS

SEATBACK ADJUSTMENT

The seatback may be positioned to four different angles: 90°, 100°, 102°, and 105°. See figure 15.

To adjust the seatback angle:

1. Loosen and remove the adjustment screw from both seatback hinges.
2. Reposition the seatback to the desired angle.
3. Align the adjustment holes from the upper and lower hinge, so the adjustment screw can easily pass through.
4. Reinsert both adjustment screws and tighten.

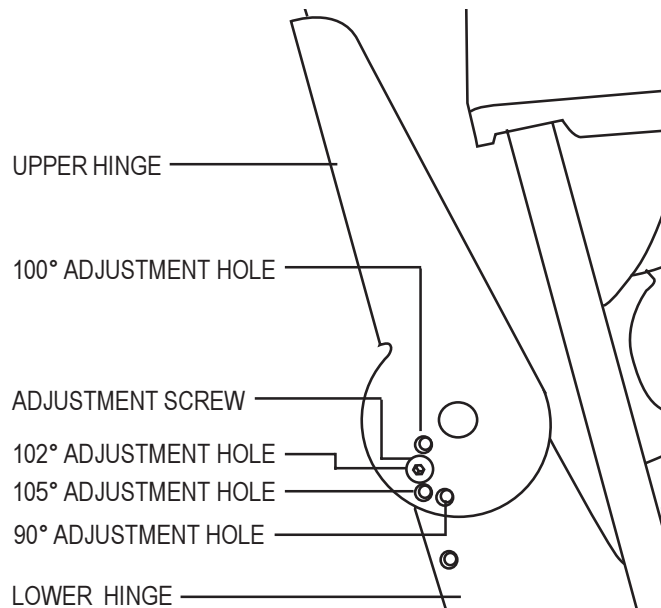

FIGURE 15. SEATBACK HINGE

POWER SEAT ACTUATOR (OPTIONAL)

Your Legend may be equipped with a power seat actuator which raises and lowers the seat automatically. See figure 16.



WARNING! The power seat mechanism is intended for operation only while the vehicle is stationary and on a level surface. Its purpose is to aid you in reaching objects. Strict adherence to the following safety rules is vital to your safety: Do not attempt to raise or lower the seat while in motion! Do not operate your Scooter with the power seat elevated. It is recommended that the vehicle be driven only with the seat in the lowest position.



FIGURE 16. POWER SEAT ACTUATOR (OPTIONAL)

IX. DISASSEMBLY AND ASSEMBLY

No tools are required to disassemble or assemble your Legend. Always disassemble or assemble your Legend on a level, dry surface with sufficient room for you to work and move around your Scooter. Keep in mind that the disassembled sections of the Legend takes up more floor space than the assembled Legend.

DISASSEMBLY

You can disassemble the Legend into six pieces: the seat, the front section, the rear section, the rear shroud, and the batteries. You can also remove the utility tray to lighten the weight of the rear section if necessary. Place the Scooter in an area where you have sufficient clearance to move the parts around. You need about four or five feet in all directions. You may need assistance to lift some of the Scooter's components. See IV. "Specifications" for individual component weights.

1. Place the manual freewheel lever in the drive (down) position.
2. Unplug the charger, coil the cord, and store it in the rear compartment.
3. Push down on the seat lock lever to unlock the seat and lift the seat up and off of the Legend. See figure 17.
4. Gently lift the rear shroud off of the Legend. See figure 18.
5. Unplug the large, white, 9-pin front-to-rear harness. See figure 19.
6. Unplug both 2-pin, black and white battery harnesses and lift both batteries off of the Legend. See figures 20 and 21.



CAUTION! Failure to unplug both battery harnesses and the front-to-rear harness prior to disassembly could result in permanent damage to the Legend.

7. If removing the utility tray, unplug the black 6-pin motor harness. See figure 22. The utility tray is held in place with reusable fasteners; to remove it, gently pull the tray straight up and off the Scooter.
8. Grab the handle grip on the tiller, pull upward on the release lever, and gently lower the tiller down to the center of the Legend chassis until it is fully lowered.
9. Remove both ball detent pins and lift up the frame lock levers. See figures 23 and 24.
10. Slide the front and rear sections apart. See figure 25.



FIGURE 17. SEAT REMOVAL



FIGURE 18. SHROUD REMOVAL

IX. DISASSEMBLY AND ASSEMBLY



FIGURE 19. DISCONNECTING THE FRONT-TO-REAR HARNESS

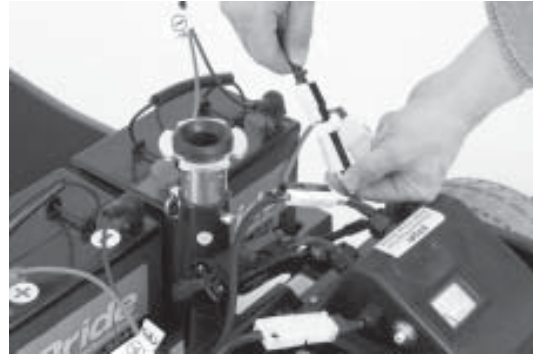

FIGURE 20. DISCONNECTING THE 2-PIN BATTERY HARNESS



FIGURE 21. BATTERY REMOVAL

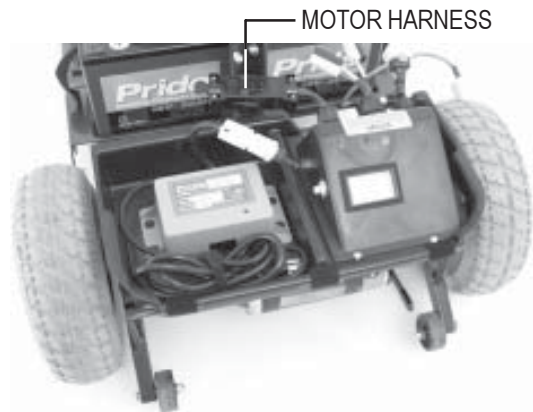

FIGURE 22. DISCONNECTING THE MOTOR HARNESS



FIGURE 23. REMOVE BALL DETENT PINS



FIGURE 24. LIFT UP FRAME LOCK LEVER TO UNLOCK



FIGURE 25. SEPARATING THE FRAME

IX. DISASSEMBLY AND ASSEMBLY

ASSEMBLY

1. Push the manual freewheel lever in the drive (down) position.
2. Position the front and rear sections next to each other.
3. Tilt the rear end to a horizontal position, insert the longer tube of the front end into the rear section first, and make sure that the frame locking levers are vertically positioned and the locking pins are removed.
4. Slide the two sections of the unit together until the front half reaches its insertion limit.
5. Secure the front and rear sections with ball detent pins.
6. Push the frame lock levers back to their locked (downward) position.
7. Join the large, white, 9-pin front-to-rear harness. The two orange dots present on both harnesses should be adjacent to each other and enable quick plug mating.
8. Put the batteries in place and plug the 2-pin battery harnesses into the adjoining harnesses that extend from the electronic controller assembly.
9. To reinstall the utility tray if it has been removed, be sure the tray is firmly pressed down on the reusable fasteners that holds it to the Scooter, then reconnect the black 6-pin motor harness.
10. Carefully lower the rear shroud over the seat pedestal and down into place. Make sure the rear plastic shroud does not make any contact with the rear wheels.
11. Carefully lift the seat and slide the small seat post (on the seat bottom) into the seat pedestal.
12. Rotate the seat until it locks into place.

X. OPTIONAL ACCESSORIES

For information concerning these accessories, see your authorized Pride provider.

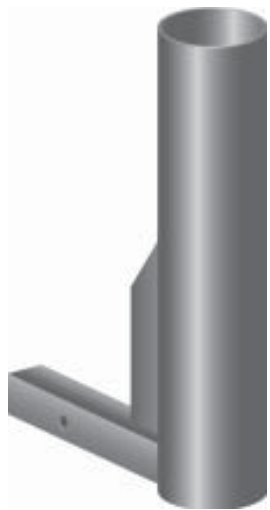

• SINGLE CANE/CRUTCH HOLDER

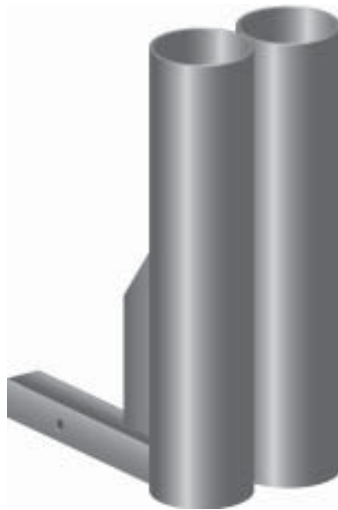

• DOUBLE CANE/CRUTCH HOLDER



• OXYGEN TANK HOLDER



• REAR BASKET



• WALKER HOLDER



• FOREARM CRUTCH HOLDER



• CUP HOLDER



• SAFETY FLAG

XI. BASIC TROUBLESHOOTING

Any electromechanical device occasionally requires some troubleshooting. However, most of the problems that may arise can usually be solved with a bit of thought and common sense. Many of these problems occur because the batteries are not fully charged, or because the batteries are worn down and can no longer hold a charge.

What if all the systems on my Legend seem to be “dead”?

- Make certain that the key is fully inserted in the key switch.
- Check that the batteries are fully charged. See VI. “Batteries and Charging.”
- Push in the reset button to reset the main circuit breaker. See V. “Your Legend.”
- Make certain that both black and white battery harnesses are firmly connected. See IX. “Disassembly and Assembly.”
- Make sure all battery cables are connected to the battery terminals and the wing nuts are tightened.
- Make sure that the front-to-rear harness is firmly connected. See IX. “Disassembly and Assembly.”

What if the motor runs but my Legend does not move?

- Your Legend was probably left in manual freewheel mode.
- When the manual freewheel lever is pulled up, the brakes are disengaged and all power to the transaxle is cut.
- Push down the manual freewheel lever to restore normal operation to your Legend. See V. “Your Legend.”

What if the main circuit breaker repeatedly trips? See V. “Your Legend.”

- Charge the Legend’s batteries more frequently. See VI. “Batteries and Charging.”
- If the problem continues, have both of your Legend’s batteries load tested by your authorized Pride provider.
- Or, battery load testers are available at most automotive parts stores.
 - Follow the directions supplied with the load tester.
 - See VI. “Batteries and Charging” or IV. “Specifications” for information about your Legend’s battery type.

What if the battery condition meter dips way down and the motor surges or hesitates when I press my Legend’s throttle control lever? See V. “Your Legend.”

- Fully charge your Legend’s batteries. See VI. “Batteries and Charging.”
- Have your authorized Pride provider load test each battery.
- Or, see the previous troubleshooting question for load testing the batteries yourself.

If you experience any problems with your Legend that you are not able to solve, immediately contact your authorized Pride provider for information, maintenance, and service.

XII. CARE AND MAINTENANCE

Your Legend requires a minimal amount of care and maintenance. If you do not feel confident in your ability to perform the maintenance listed below, you may schedule inspection and maintenance at your authorized Pride provider. The following areas require periodic inspection and/or care and maintenance.

TIRE PRESSURE

- For optimum Scooter performance we recommend that the tire pressure be maintained at 30-35 psi.



WARNING! Do not exceed 35 psi; overinflating a tire can cause it to explode.

- Regularly inspect your Legend's tires for signs of wear.
- Use a rubber conditioner on your Legend's tires to help to preserve them.
- Do not put rubber conditioner on tire tread; this may cause the tires to become dangerously slippery.

EXTERIOR SURFACES

- Bumpers and trim also benefit from an occasional application of rubber or vinyl conditioner.



WARNING! Do not apply a rubber or vinyl conditioner on the Scooter's vinyl seat or tire tread; they will become dangerously slippery.

BATTERY TERMINAL CONNECTIONS

- Make certain that the terminal connections remain tight and uncorroded.
- The batteries must sit flat in the battery wells.
- The battery terminals should face the rear of the Legend.

WIRING

- Regularly check all wiring connections.
- Regularly check all wiring insulation, including the charger power cord, for wear or damage.
- Have your authorized Pride provider repair or replace any damaged harness, connection, or insulation that you find before using your Legend again.

ABS PLASTIC SHROUDS

- The control console assembly shroud, front shroud, and the rear shroud are formed from durable ABS plastic and coated with an advanced formula urethane paint.
- A light application of car wax will help the shrouds retain their high gloss.

AXLE BEARINGS AND THE MOTOR/TRANSAXLE ASSEMBLY

- These items are all prelubricated, sealed, and require no subsequent lubrication.

MOTOR BRUSHES

- The motor brushes are housed inside of the motor transaxle/assembly. They should be inspected periodically for wear by your authorized Pride provider.

CONSOLE, CHARGER, AND ELECTRONIC CONTROLLER ASSEMBLY

- Keep these areas free of moisture.
- If any of these items do become exposed to moisture, let them dry thoroughly before operating your Legend again.

XIII. WARRANTY

THREE-YEAR LIMITED WARRANTY

Three years on all structural frame components; including platform, fork, seat post, and frame.

Three year prorata drive train warranty (including transaxle, motor, and brake.)

- First year: 100% replacement of parts cost
- Second year: 67% replacement of parts cost
- Third year: 50% replacement of parts cost

THREE-YEAR WARRANTY EXCEPTIONS

Transaxle: In cases where there is an increase in the operational noise level, the warranty does not apply. (The increase in operational noise level usually occurs due to abusive and excessive strain on the Scooter.)

Motor: If damage occurs to the motor commutator as a result of not replacing the motor brushes after heavy wear to the brushes. Motor brushes are wear items and are not warranted.

Motor brake: Three-year warranty for the electrical function of the motor brake. Brake pads are a wear item and are not warranted.

ONE-YEAR LIMITED WARRANTY

For one (1) year from the date of purchase, Pride will repair or replace, at our option, to the original purchaser, free of charge, any part found upon examination by an authorized representative of Pride to be defective in material and/or workmanship.

The battery is warranted by the battery manufacturer. The battery is not warranted by Pride.

Warranty service can be performed by a provider authorized by Pride or by Pride. Do not return faulty parts to Pride without prior consent. All transportation costs and shipping damage incurred while submitting parts for repair or replacement are the responsibility of the original purchaser.

WARRANTY EXCLUSIONS

- ABS plastic shrouds and floorboard covers (wear items and not warranted)
- Batteries (the battery manufacturer provides a six-month limited warranty)
- Tires and tire tubes (wear items and not warranted)
- Upholstery and seating (wear items and not warranted)
- Repairs and/or modifications made to any part of the Scooter without specific and prior consent from Pride
- Circumstances beyond the control of Pride
- Damage caused by:
 - Battery fluid spillage or leakage
 - Abuse, misuse, accident, or negligence
 - Improper operation, maintenance, or storage
 - Commercial use or use other than normal
- Labor, service calls, shipping, and other charges incurred for repair of the product

XIII. WARRANTY

There is no other express warranty.

Implied warranties, including those of merchantability and fitness for a particular purpose, are limited to one (1) year from the date of original purchase and to the extent permitted by law. Any and all implied warranties are excluded. This is the exclusive remedy. Liabilities for consequential damages under any and all warranties are excluded.

Some states do not allow limitations on how long an implied warranty lasts or do not allow the exclusion of limitation of incidental or consequential damages. So, the above limitation or exclusion may not apply to you.

NOTES

NOTES